



Product Catalogue 2024

Building Material Plants –
In-Plant Handling

Truck Crane Attachments

List of contents



Building Material Plants – In-Plant Handling

| | |
|--|----|
| | 6 |
| 10 Pavers and Blocks | 9 |
| 11 Pipes and Manholes | 23 |
| 12 Special Devices | 33 |
| 13 Vacuum Technology | 37 |
| 14 Components for Fully Automatic Plants | 53 |



Truck Crane Attachments

| | |
|---------------------------------|----|
| | 54 |
| 15 Attachments for Truck Cranes | 57 |

Service

| | |
|--------------------------|----|
| | 64 |
| After Sales / Warranty | 65 |
| General Sales Conditions | 66 |
| Product Request Form | 68 |

making hard work easier

**We are the top supplier for
today's building material
handling, making hard work
easier.**



For over 60 years, our tools and machines have been making your everyday work on the construction site easier. Thanks to many important ergonomic and efficiency-enhancing innovations, we are now world market leader and set the standards in building materials handling on construction sites and in concrete plants.

More than 190 employees find the optimal solution for you every day – worldwide at our locations in Germany, Great Britain, France, Italy, Poland, Korea, Canada, USA and in Australia. With more than 1,700 sales partners worldwide, including over 700 in Germany, you have a competent partner at your side wherever you are.

Since 2020, the entire group of companies has been climate-neutral.



INNOVATION AWARD FOR ERGONOMICS 2022



CLIMATE NEUTRAL COMPANY
certified by Fokus Zukunft

1.700

Sales partner worldwide

190

Employees worldwide

8

Subsidiaries worldwide

Alphabetical Index

Listed by Acronym

| Acronym | Product Name | Page |
|------------------------|---|------|
| AG | Setting Up Device for Manhole Rings AG | 25 |
| AKZ-UNI | Block Loading Grabs AKZ-UNI | 57 |
| AKZ-UNI-H | Block Loading Grabs AKZ-UNI-H | 58 |
| ASSK | Pillar Swing Crane ASSK | 52 |
| ASZ | Sorting Clamp ASZ | 34 |
| ASZ-P | Pneumatic Sorting Clamp ASZ-P | 35 |
| ATZ-P | Pneumatic Cubing Clamp ATZ-P | 20 |
| AWSK | Wall Swing Crane AWSK | 51 |
| BE-ERGOSPRINT | Ergonomic Vacuum Control Unit BE-ERGOSPRINT | 43 |
| BE-SPRINT-2 | Operating Valve Unit BE-SPRINT-2 | 42 |
| DLH | Not turnable lifting hook DLH | 62 |
| ESP | Suction Plates ESP | 44 |
| ESP-SW | Tilteable suction plate ESP-SW | 48 |
| ESP-SW-P-250-A | Pneumatic swivelling base frame for use with exchangeable suction plates ESP-SW-P-250 | 49 |
| ET | Fork Sleeves with manual device engaging ET | 62 |
| FUG | Small Pipe Turning Device FUG | 29 |
| GB | Rubber Gripper GB | 59 |
| GB2 | Rubber Gripper GB2 | 11 |
| GB2-Z | Rubber gripper GB2-Z | 12 |
| HE | Lifting Hose Units HE | 42 |
| JWK | Jumbo Travelling Crane JWK | 41 |
| KA | Crane Boom KA | 15 |
| KA-I-VA | Crane Boom with Distance Adjustment KA + VA | 16 |
| KA-I-VA-SV | Crane Boom with Distance Adjustment and Side Shift KA + VA + SV | 16 |
| KIG | Cone Insert Clamp KIG | 23 |
| KT | Tilting Table KT | 31 |
| MFD | Multiple Forks MFD | 30 |
| MFS | Multiple Suction Plates MFS | 46 |
| MSP | Multiple Suction Plate MSP-3-S-150-3x22Rd | 45 |
| P-WG | Pneumatic Rotating Clamp P-WG | 35 |
| PD | Hydraulic Swing Damper PD | 18 |
| PGH | Pallet Forks PGH | 63 |
| Pressure Plates | Pressure Plates STAZ-UNI-4 | 13 |
| PWG-R | Gantry Crane Rotating Clamp for Concrete Pipes PWG-R | 31 |
| PWG-S | Gantry Crane – Rotating Clamp for Manhole Rings and Basers PWG-S | 27 |
| QT | Spreader Bar QT | 17 |
| RK-I/-II/-III | Manhole Ring Clamp RK-I/-II/-III | 24 |
| RK-XL-IV/-V/-VI | Manhole Ring Clamp RK-XL-IV/-V/-VI | 30 |
| RKG | Ring- and Cone Clamp RKG | 26 |
| RKZ-H | Ring- and Cone Clamp RKZ-H | 26 |
| SRF-900 | Vertical Guide SRF-900 | 21 |
| STAZ-DZ-I | Double Fork Lift Grab STAZ-DZ-I | 33 |
| STAZ-DZ-II | Double Fork Lift Grab STAZ-DZ-II | 11 |
| STAZ-KS | Fork Lift Grab STAZ-KS | 33 |
| STAZ-SLC | Selective Layer Clamp STAZ-SLC | 10 |
| STAZ-UNI | Fork Lift Grab STAZ-UNI | 9 |
| STAZ-UNI-4 | Fork Lift Grab STAZ-UNI-4 | 10 |
| STAZ-UNI-P/STAZ-UNI-KA | Fork Lift Grab STAZ-UNI-P/STAZ-UNI-KA | 34 |
| STB1-S2 | Steel Finger Gripper STB1-S2 | 13 |
| SWV | Quick Change Device SWV | 60 |
| SWV-HE | Quick Change Device SWV-HE | 44 |
| SZV | Hose Cylinder Extension SZV | 43 |
| UG | Turning Device for Concrete Pipes UG | 28 |
| UMG | Steel Pallet Grab UMG | 28 |
| VAH-12 | Vacuum Sorting Lifter VAH-12 | 37 |
| VGE-230 | Vacuum Turbine Unit VGE-230 | 50 |
| VGE-SB | Vacuum Turbine Unit VGE-SB | 50 |
| VXS | VACUSPEED VXS | 38 |

| Acronym | Product Name | Page |
|---------------|---|------|
| VXS-ASSK-65-4 | Pillar Swing Crane VXS-ASSK-65-4 | 39 |
| VXS-AWSK-65-4 | Wall Swing Crane VXS-AWSK-65-4 | 40 |
| WG-R | Rotating Clamp for Concrete Pipes WG-R | 29 |
| WG | Turning Device for Concrete Bases WG/WG-S | 27 |
| WSP | Angeled Suction Plates WSP | 45 |

Alphabetical Index

Listed by Product Name

| Product Name | Acronym | Page |
|---|------------------------|------|
| Angeled Suction Plates WSP | WSP | 45 |
| Block Loading Grabs AKZ-UNI | AKZ-UNI | 57 |
| Block Loading Grabs AKZ-UNI-H | AKZ-UNI-H | 58 |
| Cone Insert Clamp KIG | KIG | 23 |
| Crane Boom KA | KA | 15 |
| Crane Boom with Distance Adjustment and Side Shift KA + VA + SV | KA + VA + SV | 16 |
| Crane Boom with Distance Adjustment KA + VA | KA + VA | 16 |
| Double Fork Lift Grab STAZ-DZ-I | STAZ-DZ-I | 33 |
| Double Fork Lift Grab STAZ-DZ-II | STAZ-DZ-II | 11 |
| Ergonomic Vacuum Control Unit BE-ERGOSPRINT | BE-ERGOSPRINT | 43 |
| Fork Lift Grab STAZ-KS | STAZ-KS | 33 |
| Fork Lift Grab STAZ-UNI | STAZ-UNI | 9 |
| Fork Lift Grab STAZ-UNI-4 | STAZ-UNI-4 | 10 |
| Fork Lift Grab STAZ-UNI-P/STAZ-UNI-KA | STAZ-UNI-P/STAZ-UNI-KA | 34 |
| Fork Sleeves with manual device engaging ET | ET | 62 |
| Gantry Crane Rotating Clamp for Concrete Pipes PWG-R | PWG-R | 31 |
| Gantry Crane – Rotating Clamp for Manhole Rings and Basers PWG-S | PWG-S | 27 |
| Hose Cylinder Extension SZV | SZV | 43 |
| Hydraulic Swing Damper PD | PD | 18 |
| Jumbo Travelling Crane JWK | JWK | 41 |
| Lifting Hose Units HE | HE | 42 |
| Manhole Ring Clamp RK-I/-II/-III | RK-I/-II/-III | 24 |
| Manhole Ring Clamp RK-XL-IV/-V/-VI | RK-XL-IV/-V/-VI | 30 |
| Multiple Forks MFD | MFD | 30 |
| Multiple Suction Plate MSP-3-S-150-3x22Rd | MSP-3-S-150-3x22Rd | 45 |
| Multiple Suction Plates MFS | MFS | 46 |
| Not turnable lifting hook DLH | DLH | 62 |
| Operating Valve Unit BE-SPRINT-2 | BE-SPRINT-2 | 42 |
| Pallet Forks PGH | PGH | 63 |
| Pillar Swing Crane ASSK | ASSK | 52 |
| Pillar Swing Crane VXS-ASSK-65-4 | VXS-ASSK-65-4 | 39 |
| Pneumatic Cubing Clamp ATZ-P | ATZ-P | 20 |
| Pneumatic Rotating Clamp P-WG | P-WG | 35 |
| Pneumatic Sorting Clamp ASZ-P | ASZ-P | 35 |
| Pneumatic swivelling base frame for use with exchangeable suction plates ESP-SW-P-250 | ESP-SW-P-250 | 49 |
| Quick Change Device SWV | SWV | 60 |
| Quick Change Device SWV-HE | SWV-HE | 44 |
| Ring- and Cone Clamp RKG | RKG | 26 |
| Ring- and Cone Clamp RKZ-H | RKZ-H | 26 |
| Rotating Clamp for Concrete Pipes WG-R | WG-R | 29 |
| Rubber Gripper GB | GB | 59 |
| Rubber Gripper GB2 | GB2 | 11 |
| Rubber gripper GB2-Z | GB2-Z | 12 |
| Selective Layer Clamp STAZ-SLC | STAZ-SLC | 10 |
| Setting Up Device for Manhole Rings AG | AG | 25 |
| Small Pipe Turning Device FUG | FUG | 29 |
| Sorting Clamp ASZ | ASZ | 34 |
| Spreader Bar QT | QT | 17 |
| Steel Finger Gripper STB1-S2 | STB1-S2 | 13 |
| Steel Pallet Grab UMG | UMG | 28 |
| Suction Plates ESP | ESP | 44 |
| Tilteable suction plate ESP-SW | ESP-SW | 48 |
| Tilting Table KT | KT | 31 |
| Turning Device for Concrete Bases WG/WG-S | WG/WG-S | 27 |
| Turning Device for Concrete Pipes UG | UG | 28 |
| VACUSPEED VXS | VXS | 38 |
| Vacuum Sorting Lifter VAH-12 | VAH-12 | 37 |

| Product Name | Acronym | Page |
|--------------------------------|---------------|------|
| Vacuum Turbine Unit VGE-230 | VGE-230 | 50 |
| Vacuum Turbine Unit VGE-SB | VGE-SB | 50 |
| Vertical Guide SRF-900 | SRF-900 | 21 |
| Wall Swing Crane AWSK | AWSK | 51 |
| Wall Swing Crane VXS-AWSK-65-4 | VXS-AWSK-65-4 | 40 |



Building Material Plants – In-Plant Handling

Speed up your material flow in the factory

Storage and retrieval, order picking and transport

Speed up your material flow in the plant with our solutions for building material dealers and concrete plants. Probst offers efficient solutions, such as the hydraulic forklift grabs STAZ or the mechanical manhole ring clamps RK.

Vacuum technology is one of Probst's specialities. This technology shows its strengths especially when picking concrete products – for efficient, ergonomic work.

Practical solutions – individually tailored

Apart from the broad standard range of products, our team also develops individual special solutions together with you, tailored to your challenge – with the result of making your hard work easier.





STAZ-UNI

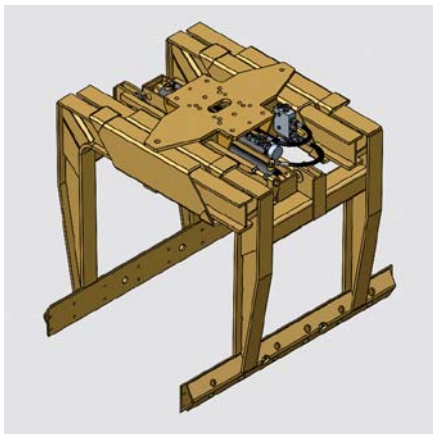

STAZ-UNI

Fork Lift Grab STAZ-UNI

Specially designed for heavy duty work with fork lift trucks.

For gripping heavier loads, or packs produced on multi-layer production machines. In particular used in conjunction with steel finger grippers. Can also be used for gripping packs of pavers which are not vertically steel strapped.

- Light-weight, yet with a high carrying capacity due to the use of high-tensile steel for load-bearing parts.
- Can fit all the usual packs of building materials due to a large opening range and to the exchangeable grippers which come in various lengths and designs.
- Fully hydraulic parallel opening range. Low-maintenance steel-plastic sliding guides.
- Manually adjustable pressure relief valve.
- Oil Pressure Gauge.
- Plastic sliding guides come with a 5 year guarantee.

| Type | Inside Height mm (in) | Dead Weight kg (lbs) | Hydraulic Connection Pressure bar (psi) | Opening Width Main Gripper mm (in) | Working Load Limit/WLL kg (lbs) | Gripper Base Length Main Gripper mm (in) | Order-Number |
|----------------------|--------------------------|-------------------------|--|--|---------------------------------------|--|----------------------|
| STAZ-UNI-0700 | 700 (27.56) | 500 (1,102) | 180 – 210 (2,611 – 3,046) | 370 – 1,370 (14.57 – 53.94) | 4,000 (8,818) | 1,250 (49.21) | 57000700-1250 |
| STAZ-UNI-0850 | 850 (33.46) | 505 (1,113) | 180 – 210 (2,611 – 3,046) | 370 – 1,370 (14.57 – 53.94) | 4,000 (8,818) | 1,250 (49.21) | 57000850-1250 |
| STAZ-UNI-1000 | 1,000 (39.37) | 525 (1,157) | 180 – 210 (2,611 – 3,046) | 370 – 1,370 (14.57 – 53.94) | 3,750 (8,267) | 1,250 (49.21) | 57001000-1250 |
| STAZ-UNI-1200 | 1,200 (47.24) | 560 (1,235) | 180 – 210 (2,611 – 3,046) | 370 – 1,370 (14.57 – 53.94) | 3,250 (7,165) | 1,250 (49.21) | 57001200-1250 |
| STAZ-UNI-1300 | 1,300 (51.18) | 575 (1,268) | 180 – 210 (2,611 – 3,046) | 370 – 1,370 (14.57 – 53.94) | 3,000 (6,614) | 1,250 (49.21) | 57001300-1250 |
| STAZ-UNI-1350 | 1,350 (53.15) | 585 (1,290) | 180 – 210 (2,611 – 3,046) | 370 – 1,370 (14.57 – 53.94) | 3,000 (6,614) | 1,250 (49.21) | 57001350-1250 |
| STAZ-UNI-1400 | 1,400 (55.12) | 595 (1,312) | 180 – 210 (2,611 – 3,046) | 370 – 1,370 (14.57 – 53.94) | 2,750 (6,063) | 1,250 (49.21) | 57001400-1250 |
| STAZ-UNI-1550 | 1,550 (61.02) | 610 (1,345) | 180 – 210 (2,611 – 3,046) | 370 – 1,370 (14.57 – 53.94) | 2,500 (5,512) | 1,250 (49.21) | 57001550-1250 |

011223 Technical data contained in this catalogue can be modified without prior notice in the interest of progress. Illustrations are exemplary and non-binding. No liability accepted for any misprints, mistakes and errors.



STAZ-UNI-4 + fork sleeve + pressure plates

Fork Lift Grab STAZ-UNI-4

Specially designed for the safe gripping of un-strapped and un-compressed stacks of multilayer production.

The same characteristics as the STAZ-UNI but equipped with a four-sided clamping action. Because the main and the end gripping is hydraulically controlled separately, and by using pressure plates (accessory), an exact Two compression of the stacks and the elimination of any gaps are achieved.

Separate hydraulic circuits are necessary to be supplied by the fork lift truck. (Supplied without connecting hoses to the fork lift truck).

Required jaw lengths depending on the dimensions of the stone layer. Contoured grippers for special layers on special request.

| Type | Inside Height mm (in) | Dead Weight kg (lbs) | Hydraulic Connection Pressure bar (psi) | Opening Width Side Gripper mm (in) | Opening Width Main Gripper mm (in) | Working Load Limit/ WLL kg (lbs) | Order-Number |
|------------------------|--------------------------|-------------------------|--|---------------------------------------|---------------------------------------|-------------------------------------|-----------------|
| STAZ-UNI-4-850 | 850 (33.46) | 765 (1,687) | 180 – 210 (2,611 – 3,046) | 900 – 1,400 (35.43 – 55.12) | 550 – 1,230 (21.65 – 48.43) | 3,000 (6,614) | 57000165 |
| STAZ-UNI-4-1000 | 1,000 (39.37) | 810 (1,786) | 180 – 210 (2,611 – 3,046) | 900 – 1,400 (35.43 – 55.12) | 550 – 1,230 (21.65 – 48.43) | 3,250 (7,165) | 57000166 |
| STAZ-UNI-4-1200 | 1,200 (47.24) | 940 (2,072) | 180 – 210 (2,611 – 3,046) | 900 – 1,400 (35.43 – 55.12) | 550 – 1,230 (21.65 – 48.43) | 3,500 (7,716) | 57000167 |



Selective Layer Clamp STAZ-SLC

Specially designed to help select one or several layers of stones with a fork lift truck.

Without connecting hoses to the fork lift truck, without fork sleeves and without rubber grippers, see accessories.

- Manually adjustable pressure relieve valve.
- Oil Pressure Gauge.
- Has an integrated, adjustable height stop, controlled by the gripping function, only one hydraulic circuit is necessary.
- Adjustable height stop is being controlled by a scissor system – it therefore reduces the necessary space required.
- Low maintenance Steel–Plastic–Sliding Guide.

| Type | Inside Height mm (in) | Dead Weight kg (lbs) | Hydraulic Connection Pressure bar (psi) | Opening Width Main Gripper mm (in) | Working Load Limit/WLL kg (lbs) | Gripper Base Length Main Gripper mm (in) | Order-Number |
|-----------------|------------------------------|-------------------------|--|--|------------------------------------|--|-----------------|
| STAZ-SLC | 500 / 700 (19.69 / 27.56) | 367 (809) | 180 – 210 (2,611 – 3,046) | 370 – 1,370 (14.57 – 53.94) | 1,500 (3,307) | 1,250 (49.21) | 57050034 |



STAZ-DZ-II

Double Fork Lift Grab STAZ-DZ-II

Consisting of two single clamps (see STAZ-UNI for technical data). Connected by a spreader bar. Suitable for lifting 2 stacks at the same time if they are stacked longitudinally on the conveyor belt. The same unit can be equipped with a hydraulically operated distance adjuster bar which can remove any gaps between the stacks, thus saving space in the storage area. Supplied without connecting hoses to the fork lift truck.

- Only one hydraulic circuit is needed to be supplied by means of the fork lift truck, if both clamps are operated together.
- Plastic sliding guides come with a 5 year guarantee.

| Type | Order-Number |
|------------|--------------|
| STAZ-DZ-II | On Request |

Grippers for Fork Lift Grabs STAZ

To make the fork lift grabs as versatile as possible there are grippers available for every type of use. The following grippers are available for standard usage:

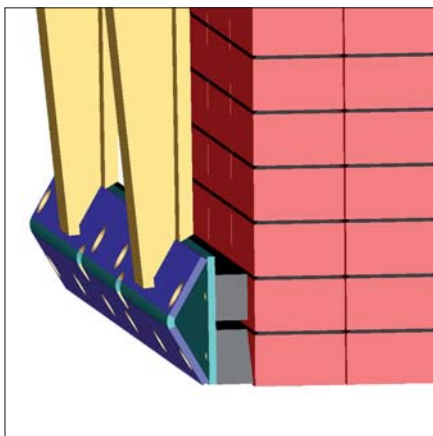

GB2

Rubber Gripper GB2

Light-weight, suitable for all models and available in various lengths.

The gripping element consists of highly durable exchangeable rubber-metal bars screwed to a substructure.

Thick rubber linings ensure a careful handling of delicate concrete products.

2 rows of rubber metal bars and a conical lower rubber surface strengthen the gripping pressure on the lowest row of blocks.

Applications:

Stacks of large concrete elements.

Stacks of paving blocks, each row vertically steel-strapped.

Stacks of paving blocks which are either not, or only partly, vertically steel-strapped and which are produced on a single layer machine with gripping width up to 700 mm (27.55 inch) and a minimum thickness of 60 mm. (2.36 inch). Limited use for stacks of paving blocks which are either not, or only partly, vertically steel-strapped and which are produced on a multi-layer machine, with a gripping width above 700 mm (27.55 inch) and a minimum thickness of 80 mm. (3 inch).

| Type | Length of Gripper mm (in) | Dead Weight kg (lbs) | Quantity Pieces | Order-Number |
|----------|---------------------------|----------------------|-----------------|---------------|
| GB2-0720 | 720 (28.35) | 12.5 (28) | 1 | 47451000-0720 |
| GB2-0780 | 780 (30.71) | 14 (31) | 1 | 47451000-0780 |
| GB2-0850 | 850 (33.46) | 15 (33) | 1 | 47451000-0850 |
| GB2-1000 | 1,000 (39.37) | 16.5 (36) | 1 | 47451000-1000 |
| GB2-1100 | 1,100 (43.31) | 18.5 (41) | 1 | 47451000-1100 |
| GB2-1200 | 1,200 (47.24) | 20 (44) | 1 | 47451000-1200 |
| GB2-1250 | 1,250 (49.21) | 21 (46) | 1 | 47451000-1250 |
| GB2-1300 | 1,300 (51.18) | 22 (49) | 1 | 47451000-1300 |

011223 Technical data contained in this catalogue can be modified without prior notice in the interest of progress. Illustrations are exemplary and non-binding. No liability accepted for any misprints, mistakes and errors.

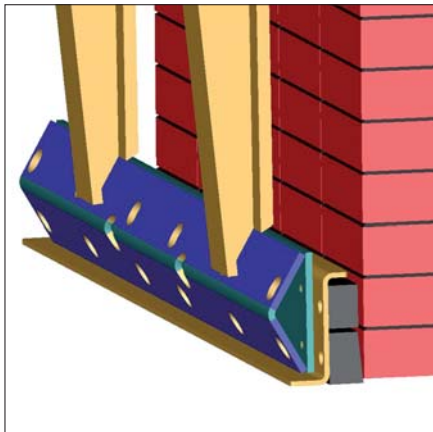

Rubber gripper GB2-Z with quick change system

Design and utilization as described as GB2, but in this case the rubber elements are secured to a Z-shape steel carrier.

The complete gripper is fixed to the body of the grab by means of 2 pins.

- When different length of grippers are needed, they can be exchanged quickly by this quick change system.

GB2-Z: 1 x rubber rail 50 x 35 mm (2 x 1.37 inch). 1 x wedge-shaped rubber rail 60 x 40/34.

GB2-Z

| Type | Length of Gripper mm (in) | Dead Weight kg (lbs) | Quantity Pieces | Order-Number |
|-------------------|---------------------------|----------------------|-----------------|----------------------|
| GB2-0720-Z | 720 (28.35) | 15.5 (34) | 1 | 47451010-0720 |
| GB2-0780-Z | 780 (30.71) | 17 (37) | 1 | 47451010-0780 |
| GB2-0850-Z | 850 (33.46) | 18 (40) | 1 | 47451010-0850 |
| GB2-1000-Z | 1,000 (39.37) | 21.5 (47) | 1 | 47451010-1000 |
| GB2-1100-Z | 1,100 (43.31) | 24 (53) | 1 | 47451010-1100 |
| GB2-1200-Z | 1,200 (47.24) | 26 (57) | 1 | 47451010-1200 |
| GB2-1250-Z | 1,250 (49.21) | 27 (60) | 1 | 47451010-1250 |
| GB2-1300-Z | 1,300 (51.18) | 28 (62) | 1 | 47451010-1300 |

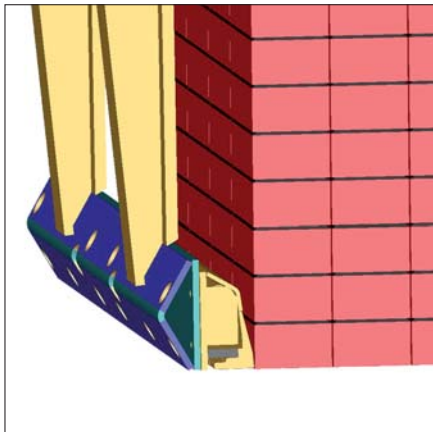

STB1-S2

Steel Finger Gripper STB1-S2

A heavy-duty design, especially developed for fork lift grabs with extra-deep gripping for transporting not vertically steel strapped pavers.

Applications:

Stacks of paving blocks which are either not, or only partly, vertically steel-strapped and which are produced on a single layer machine with a gripping width up to 850 mm (33.46 inch) and a minimum block thickness of 60 mm (2.36 inch).

Limited use for stacks which are either not or only partly vertically steel strapped and which are produced on a multi-layer machine with a gripping width up to 850 mm (33.46 inch) and a minimum block thickness of 80 mm (3 inch).

- Quickly exchangeable against rubber gripper bars GB2-Z with 2 bolts, secured by bolts.
- Single spring-steel fingers are suitable for almost all block shapes which means the safe handling of most products.

| Type | Length of Gripper mm (in) | Dead Weight kg (lbs) | Quantity Pieces | Order-Number |
|--------------|---------------------------|----------------------|-----------------|---------------|
| STB1-1000-S2 | 1,000 (39.37) | 32.5 (72) | 1 | 47451050-1000 |
| STB1-1200-S2 | 1,200 (47.24) | 37.5 (83) | 1 | 47451050-1200 |
| STB1-1250-S2 | 1,250 (49.21) | 40 (88) | 1 | 47451050-1250 |
| STB1-1300-S2 | 1,300 (51.18) | 42.5 (94) | 1 | 47451050-1300 |



Pressure Plates STAZ-UNI-4

Pressure Plates for STAZ-UNI-4

Used for compressing stacks of paving blocks (to remove any gaps between the blocks) as they are actually gripping them. Usually installed on the STAZ-UNI-4.

Solid surface, measurements adjusted to fit the gripper length and the height of the clamp.

Spring-loaded, mounted on 4 suspension points.

Required jaw lengths depending on the dimensions of the stone layer.

| Type | Description | Order-Number |
|-----------------|---------------------|--------------|
| Pressure Plates | (delivery in pairs) | 47050059 |

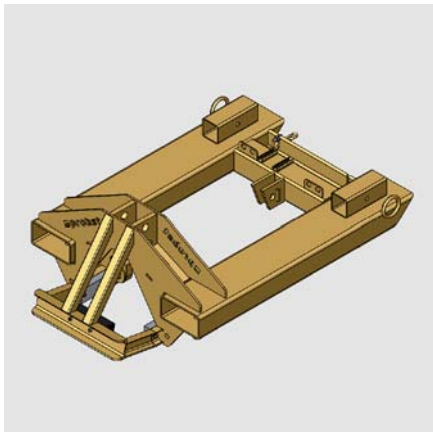

ET-IS-UNI + ETA

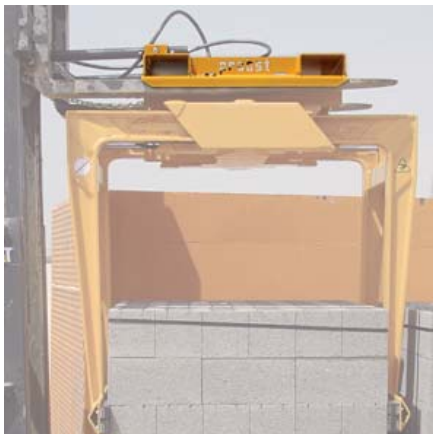

ET-E-4

Fork Sleeves for Forks

For fixing onto the fork tines, with locking device on the forks.

Various types of fork sleeves are available, depending on the jobs in hand or the attachment device:

Fork Sleeves ET-IS-UNI with cardanic suspension of the clamp:

Designed for the installation of a hydraulic rotator as well as for the installation of a hydraulic swing damper (Only suitable for STAZ and STAZ-DZ-1). With security chain to avoid slipping.
Attention: loss of lifting height (Clamp inside height + approx. 535 mm)

Fork Sleeves Fixation ETA for ET-IS-UNI:

To avoid that the ET-IS uni slips off the forks. Different reach achievable by pin-adjustment.

Fork Sleeves ET-III-UNI for single clamps:

Screwed fix to the clamp to be picked up by the forks of the fork lift truck.
Can also be installed in a 90° turn position, due to the symmetrical flange plate.
Attention: loss of lifting height (Clamp inside height + approx. 310/570 mm)

Fork Sleeves ET-E-4 for single clamps:

Screwed fix to the clamp to be picked up by the forks of the fork lift truck.
As the fork sleeves can be picked up from the front and from the side it is possible to place the STAZ-UNI grippers either lengthwise or across to the fork lift.
Attention: loss of lifting height (Clamp inside height + approx. 320/415 mm)

- Advantage: short change-over time when adding other attachments to the fork lift.

| Type | Load Extension mm (in) | Dead Weight kg (lbs) | Working Load Limit/WLL kg (lbs) | Order-Number |
|---------------------------|---------------------------|----------------------|---------------------------------|--------------|
| ET-IS-UNI-506 | 1,000 (39.37) | 140 (309) | 4,000 (8,818) | 47110074 |
| ET-IS-UNI-503-US | 1,000 (39.37) | 150 (331) | 4,000 (8,818) | 47110023 |
| ET-III-UNI for STAZ-UNI-4 | 700 (27.56) | 130 (287) | 4,000 (8,818) | 47110016 |
| ET-III-UNI for STAZ-UNI | 700 (27.56) | 130 (287) | 4,000 (8,818) | 47110019 |
| ET-E-4 | 440 – 940 (17.32 – 37.01) | 98 (216) | 4,000 (8,818) | 47110052 |

Accessories:

| Type | Description | Load Extension mm (in) | Dead Weight kg (lbs) | Order-Number |
|------|------------------------------|-------------------------------|----------------------|--------------|
| ETA | Fork Sleeves Fixation (pair) | 1,000 – 1,450 (39.37 – 57.09) | 20 (44) | 47110036 |

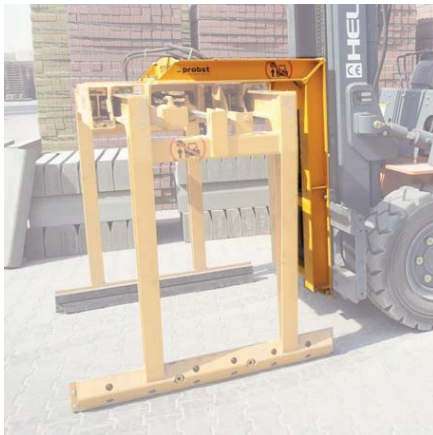

KA-ECO-1200



KA

Crane Boom KA

With a fastening for fixing directly onto the lifting plate.

Attention: Change-over time to use with forks approx. 5 minutes. Different models are available depending on the use.

- 2-arm module for good visibility for the driver.
- Hydraulic connections installed up to the end of the boom.
- Full use of the lifting height of the fork lift.

KA-ECO-1200: Crane Boom for single clamps: rigidly fitted to carriage plate, gripper jaw alignment longitudinal to the forklift truck. No loss of lifting height.

KA-I: Crane Boom for single clamps: Designed for the installation of a hydraulic rotator and also for the installation of a hydraulic swing damper (only suitable for STAZ and STAZ-DZ I).

KA-I-S: Crane Boom for single clamps: Designed for the installation of a hydraulic rotator and also for the installation of a hydraulic swing damper (only suitable for STAZ and STAZ-DZ I).

KA-II-S: Crane Boom for double clamps: Prepared to be fitted with spreader bar for double grabs.

| Type | Load Extension mm (in) | Dead Weight kg (lbs) | Working Load Limit/WLL kg (lbs) | Order-Number |
|--------------------|------------------------|----------------------|---------------------------------|-----------------|
| KA-ECO-1200 | 770 (30.31) | 165 (364) | 3,250 (7,165) | 47120078 |
| KA-I | 1,500 (59.06) | 390 (860) | 4,000 (8,818) | 47120033 |
| KA-I-S | 1,800 (70.87) | 490 (1,080) | 4,000 (8,818) | 47120034 |
| KA-II-S | 1,100 (43.31) | 550 (1,213) | 6,500 – 9,500 (14,330 – 20,944) | 47100038 |

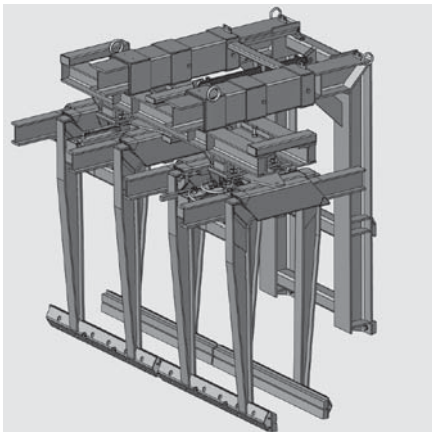

KA-II-VA

Crane Boom with Distance Adjustment KA + VA

A hydraulically extendable suspension point to extend the clamp forward of the fork lift truck.

When using the distance adjustment, take note of the following points:

The stability of the fork lift truck can be guaranteed only when the clamp is in its fully retracted position. The clamp must only be extended when the fork lift is stationary, as long as the clamp is of a maximum of 10 cm above the loading surface of the truck.

The customer must fit an optical signal. (Flashing lights or such like) to the fork lift, to warn the driver when the load is not in its fully retracted position. (For this purpose an electric contact switch is supplied with the device).

- Trucks can be loaded from one side alone.
- Useful in confined spaces.

KA-I-VA: Crane Boom for single grabs with distance adjustment.

KA-II-S-VA: Crane Boom for double grabs with distance adjustment.

| Type | Load Extension mm (in) | Dead Weight kg (lbs) | Working Load Limit/WLL kg (lbs) | Order-Number |
|-------------------|----------------------------------|----------------------|------------------------------------|-----------------|
| KA-I-VA | 1,120 – 1,800 (44.09 – 70.87) | 480 (1,058) | 4,750 (10,472) | 47120035 |
| KA-II-S-VA | 1,120 – 1,800 (44.09 – 70.87) | 690 (1,521) | 6,500 – 9,500 (14,330 – 20,944) | 47120036 |

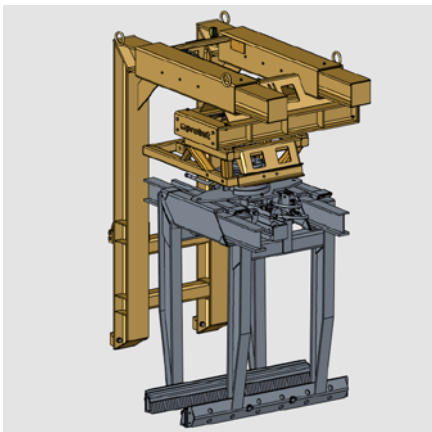

KA-I-VA-SV

Crane Boom with Distance Adjustment and Side Shift KA + VA + SV

For hydraulic shifting of the clamp`s suspension point in and across direction of travel.

- Advantage: Enables the driver of the fork lift to position the clamps exactly.

KA-I-VA-SV: Crane Boom for single grabs with distance adjustment + side shift.

| Type | Load Extension mm (in) | Dead Weight kg (lbs) | Working Load Limit/WLL kg (lbs) | Order-Number |
|-------------------|----------------------------------|----------------------|---------------------------------|-----------------|
| KA-I-VA-SV | 1,120 – 1,800 (44.09 – 70.87) | 150 (331) | 4,750 (10,472) | 47120080 |

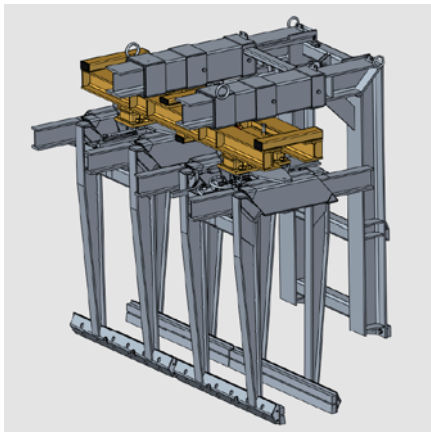

Spreader Bar QT

For double clamps, for fitting both single clamps.

Fixed model with set distance between the two clamps (QT model).

The spreader bar is firmly bolted to the clamps, yet is flexible beared in the driving direction and is fixed with individual swing dampers via rubber buffers.

Also available with hydraulic distance adjustment of the two clamps so that the distance between the packs is reduced and space is secured in the storage area (QT-H and QT-HL models).

2 x STAZ with QT + crane boom

| Type | Dead Weight kg (lbs) | Working Load Limit/WLL kg (lbs) | Shifting mm (in) | Order-Number |
|--------------|----------------------|------------------------------------|------------------------|-----------------|
| QT | 190 (419) | 6,500 – 9,500 (14,330 – 20,944) | 0 (0.00) | 47100037 |
| QT-H | 320 (705) | 6,500 – 9,500 (14,330 – 20,944) | 0 – 400 (0.00 – 15.74) | 47130019 |
| QT-HL | 320 (705) | 6,500 – 9,500 (14,330 – 20,944) | 0 – 640 (0.00 – 25.20) | 47130016 |



Hydraulic Rotator

Fitted between the clamp and the fork sleeves/crane boom, enabling stacks to be lifted and deposited, according to requirements.

DK-506

| Type | Dead Weight kg (lbs) | Working Load Limit/WLL kg (lbs) | Angle Pivoting-/Rotation Angle ° Degree | Order-Number |
|----------------|----------------------|---------------------------------|---|-----------------|
| DK-506 | 42 (93) | 6,000 (13,228) | 360 | 47150080 |
| GV-12-2 | 56 (123) | 7,500 (16,535) | 360 | 47150055 |

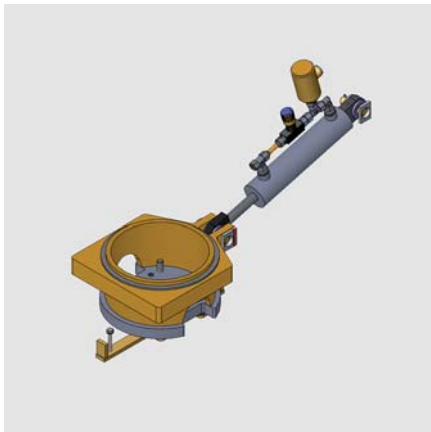

PD-S-506

Hydraulic Swing Damper PD

Fitted to control the swinging movements of the clamp when the fork lift is in motion.

Damper is longitudinally to the direction of travel by means of a hydraulic damping cylinder and diagonally to the direction of travel by means of rubber buffers. PD-V heavy-duty design with 2 damper cylinders arranged in V-stage.

| Type | Dead Weight kg (lbs) | Order-Number |
|----------|----------------------|--------------|
| PD-S-506 | 45 (99) | 47140009 |
| PD-V | 70 (154) | 47100042 |



Hydraulic Hoses HD

Hydraulic Accessories

Hydraulic Hoses

1 set = 2 hydraulic hoses including quick couplings between the fork lift and the fork sleeves or crane boom, length each approx. 1,200 mm (47.24 inch).

Electromagnetic Change Over Valve ELMV

Fitted to the clamp, in case there is only one hydraulic circuit on the side of the fork lift for “clamping” and “turning”. Supplied with the required electrical relais and push button, but not the electrical connections to the fork lift truck.

Electromagnetic Change Over Valve ELMV-DZ

Fitted to each of both clamps of the fork lift double clamp attachment STAZ-DZ II, for the separate control of the two single clamps. This means that the double clamp can be used to transport only one stack, as and when required. Supplied without electrical connections to the fork lift truck.

Electrical Connection-Kit between STAZ-DZ-II and forklift

Consisting of:

- Complete electric wiring of the attachment, installation of the components into the forklift has to be carried out by the customer.
- Spiral cable between forklift and attachment, control box and control elements.
- Turning light for warning purpose for V-attachment on crane boom KA.

Safety valve

Valve installed on grab if second release function (accidental release) in accordance with DIN EN ISO 3691-1 missing from supporting device.

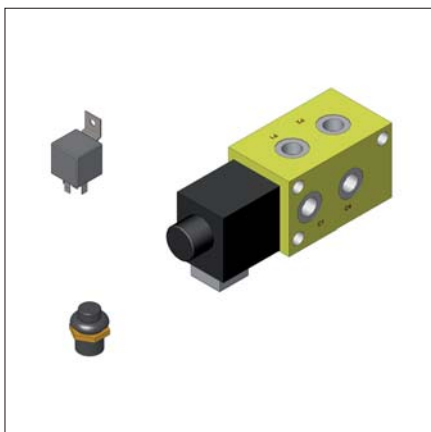

Electromagnetic Change Over Valve ELMV

| Type | Working Voltage V | Dead Weight kg (lbs) | Length mm (in) | Order-Number |
|--|-------------------|----------------------|----------------|-----------------|
| Hydraulic Hoses HD | | 5 (11) | 1,200 (47.24) | 47100047 |
| Electromagnetic Change Over Valve ELMV | 12 | 4.2 (9.26) | | 47100083 |
| Electromagnetic Change Over Valve ELMV | 24 | 4.2 (9.26) | | 47100107 |
| Set of Electromagnetic Change Over Valve ELMV-DZ | 12 | 8 (18) | | 47100207 |
| Set of Electromagnetic Change Over Valve ELMV-DZ | 24 | 8 (18) | | 47100208 |
| Electrical Connection-Kit between STAZ-DZ-II and forklift | 12 | 8.1 (18) | | 47100085 |
| Electrical Connection-Kit between STAZ-DZ-II and forklift | 24 | 8.1 (18) | | 47100154 |
| “Open” safety valve, two-way operation | 12 | 4.1 (9.04) | | 47100210 |
| “Open” safety valve, two-way operation | 24 | 4.1 (9.04) | | 47100212 |



ATZ-P-4

Pneumatic Cubing Clamp ATZ-P

Universally suitable for destacking or restacking of one or two layers of paving blocks at a time.

Mostly applied in conjunction with sandblasting machines.

Available with 2 or 4 sided clamping, depending on the size and shape of the paving blocks.

- Crane eye for attaching to crane hook.
- Pneumatic cylinder and additional manual adjustment enables a large opening range.
- Height adjustment facility.
- Fitted with manual control valve on the guiding handle.

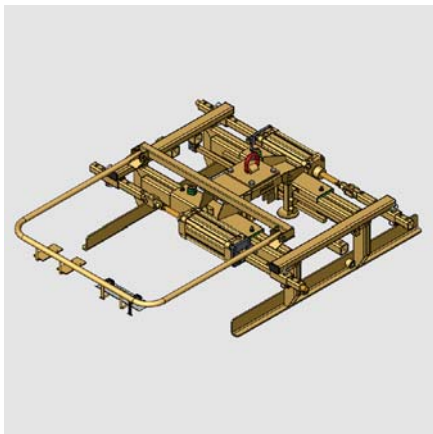

ATZ-P-2

| Type | Compressed Air Connection Pressure bar (psi) | Inside Height mm (in) | Dead Weight kg (lbs) | Opening Width Side Gripper mm (in) | Opening Width Main Gripper mm (in) | Working Load Limit/WLL kg (lbs) | Gripper Base Length Main Gripper mm (in) | Side Gripper mm (in) | Order-Number |
|---------|--|-----------------------|----------------------|------------------------------------|------------------------------------|---------------------------------|--|----------------------|--------------|
| ATZ-P-4 | 6 – 10 (87.02 – 145.04) | 160 (6.30) | 260 (573) | 760 – 1,360 (29.92 – 53.54) | 660 – 1,420 (25.98 – 55.91) | 400 (882) | 1,200 (47.24) | 850 (33.46) | 57500097 |
| ATZ-P-4 | 6 – 10 (87.02 – 145.04) | 160 (6.30) | 270 (595) | 760 – 1,360 (29.92 – 53.54) | 660 – 1,420 (25.98 – 55.91) | 600 (1,323) | 1,200 (47.24) | 850 (33.46) | 57500097-002 |
| ATZ-P-2 | 6 – 10 (87.02 – 145.04) | 160 (6.30) | 120 (265) | | 500 – 1,100 (19.69 – 43.31) | 400 (882) | 1,200 (47.24) | | 57500148 |

Accessories:

GB1: Rubber gripper in quick change system. Gripping element consisting of highly wear-resistant single-row rubber-metal rails.

| Type | Description | Length of Gripper mm (in) | Dead Weight kg (lbs) | Quantity Pieces | Order-Number |
|-------------------------------|--|------------------------------|-------------------------|--------------------|----------------------|
| Connection spiral hose | Length approx. 5,000 mm (200") / Connection 12 L. | | 3.4 (7.50) | | 22190009 |
| GB1-540-L | | 540 (21.26) | 6 (13) | 1 | 47451020-0540 |
| GB1-650-L | | 650 (25.59) | 7 (15) | 1 | 47451020-0650 |
| GB1-700-L | | 700 (27.56) | 7.5 (17) | 1 | 47451020-0700 |
| GB1-760-L | | 760 (29.92) | 8.5 (19) | 1 | 47451020-0760 |
| GB1-800-L | | 800 (31.49) | 9 (20) | 1 | 47451020-0800 |
| GB1-850-L | | 850 (33.46) | 8.5 (19) | 1 | 47451020-0850 |
| GB1-900-L | | 900 (35.43) | 10 (22) | 1 | 47451020-0900 |
| GB1-1000-L | | 1,000 (39.37) | 11 (24) | 1 | 47451020-1000 |
| GB1-1100-L | | 1,100 (43.31) | 12 (26) | 1 | 47451020-1100 |
| GB1-1200-L | | 1,200 (47.24) | 13 (29) | 1 | 47451020-1200 |
| GB1-1250-L | | 1,250 (49.21) | 13.5 (30) | 1 | 47451020-1250 |
| GB1-1300-L | | 1,300 (51.18) | 14 (31) | 1 | 47451020-1300 |



SRF-900

Vertical Guide SRF-900

Telescopic Guide for stationary equipment to lift the various devices (eg. pneumatic cubing clamp, rotating clamp or similar).

For fitting onto the available crane runway to be supplied site-wise.

Electric chain hoist (choice of lifting power), with 2 lifting speeds (electrical installation to be done by the customer).

Electric trolley with 2 speeds (electrical wiring done by the customer).

2 bottom boom carriages (unpowered), positioned suspended crossways to the direction of travel (to ease the handling of the attached devices and to improve the exact positioning of these devices).

ABUS pendant station for 4 functions, with electroflex cable.

Crane hook for lifting a piece of equipment (with manual turning device which stops itself after each 90°).

Large plastic slides for the telescopic action.

Please state the type of crane runway on request.

- Work is made easier due to the electrical travelling operation and the electric chain hoist, particularly when moving paving stone equipment. (Stock- and sand-blasting equipment) or when cubing concrete products by hand, using the appropriate device.
- Pendulum movement is considerably minimized by using the SRF.

| Type | Dead Weight kg (lbs) | Working Load Limit/WLL kg (lbs) | Order-Number |
|----------------|----------------------|---------------------------------|-----------------|
| SRF-900 | 310 (683) | 900 (1,984) | 57500008 |

011223 Technical data contained in this catalogue can be modified without prior notice in the interest of progress. Illustrations are exemplary and non-binding. No liability accepted for any misprints, mistakes and errors.



Cone Insert Clamp KIG

- Fully mechanical operation, thus making it universally suitable for cranes or fork lifts.
- Universally suitable for symmetrical and unsymmetrical cones.
- Low level fork sleeves to save lifting height.
- Exchangeable, low-wear rubber metal bars for the gentle handling of cones.
- Fully automatic change-over from "full" to "empty".
- Eyelet for cranehook to forksleeve can be fitted later on.
- Minimum changeover and attachment times.

KIG

| Type | Diameter inside mm (in) | Dead Weight kg (lbs) | Working Load Limit/WLL kg (lbs) | Order-Number |
|------------------|-----------------------------|----------------------|---------------------------------|-----------------|
| KIG-I | 625 – 800 (24.61 – 31½) | 210 (463) | 2,000 (4,409) | 57200020 |
| KIG-I-USA | 625 – 800 (24.61 – 31½) | 220 (485) | 2,000 (4,409) | 57200106 |
| KIG-II | 625 – 1,000 (24.61 – 39.37) | 280 (617) | 2,000 (4,409) | 57200208 |

011223 Technical data contained in this catalogue can be modified without prior notice in the interest of progress. Illustrations are exemplary and non-binding. No liability accepted for any misprints, mistakes and errors.



Manhole Ring Clamp RK-I/-II/-III

Also suitable for manhole rings (DIN 4034 Part 1 and 2) due to its extra-deep claws and rubber supports.

Adjusted to the dimensions of the manhole ring by bolts. As only the side wall is gripped, no radial pressure is exerted. Making it suitable for handling green products.

- Fully mechanical operation, so it can be used with any lifting equipment.
- Crane eye for attaching to crane hook.
- Fully automatic change-over from “full” to “empty”.

RK + ET



top: ET Low level fork sleeves, bottom: ET

| Type | Number of Claws Pcs. | Diameter Nominal Diameter mm (in) | Dead Weight kg (lbs) | Gripping Range mm (in) | Working Load Limit/WLL kg (lbs) | Order-Number |
|---------|----------------------|-----------------------------------|----------------------|------------------------|---------------------------------|--------------|
| RK-I | 2 | 800 – 1,500 (31.49 – 59.06) | 170 (375) | 80 – 160 (3.15 – 6.30) | 2,000 (4,409) | 57200030 |
| RK-I-US | 2 | 914 – 1,524 (35.98 – 60.00) | 240 (529) | 80 – 160 (3.15 – 6.30) | 3,200 (7,055) | 57200032 |
| RK-II | 3 | 1,500 – 2,500 (59.06 – 98.43) | 320 (705) | 80 – 160 (3.15 – 6.30) | 3,000 (6,614) | 57200033 |
| RK-III | 3 | 2,000 – 3,000 (78.74 – 118.11) | 350 (772) | 80 – 160 (3.15 – 6.30) | 3,000 (6,614) | 57200036 |

Accessories:

ET-RK with cross link: Fork sleeve for fork lift peaks. Suitable for the RK, off set design to save lifting height.

ET-RK swivel hook: Fork sleeve for fork lift peaks. Suitable for the RK, off set design to save lifting height.

ET with cross link: Fork sleeve for fork lift peaks. Suitable for RK or other devices, mounted directly above the gripper including lifting eye for attaching to crane hook.

ET 90° incl. cross link: Fork sleeve for fork lift peaks. Suitable e.g. for RK and AKZ-UNI, mounted directly above the gripper including lifting eye for attaching to crane hook. ET 90° design with manual turning device which arrests itself every 90°.

ET with cross link USA: Fork sleeve for fork lift peaks. Suitable for RK or other devices, mounted directly above the gripper including lifting eye for attaching to crane hook.

| Type | Dead Weight kg (lbs) | Working Load Limit/WLL kg (lbs) | Order-Number |
|-------------------------|----------------------|---------------------------------|--------------|
| ET-RK with cross link | 130 (287) | 3,500 (7,716) | 47200002 |
| ET-RK swivel hook | 140 (309) | 3,500 (7,716) | 47200028 |
| ET with cross link | 65 (143) | 4,000 (8,818) | 47100010 |
| ET 90° incl. cross link | 65 (143) | 4,000 (8,818) | 47110002 |
| ET with cross link USA | 65 (143) | 4,000 (8,818) | 47100106 |

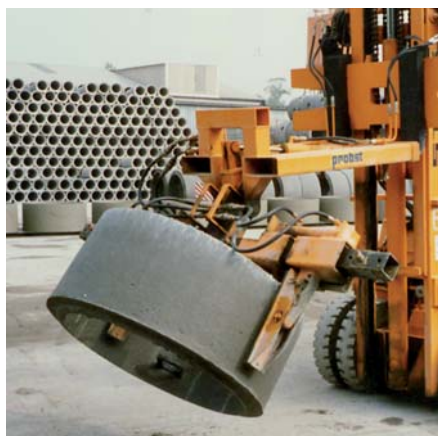

AG



AG-S

Setting Up Device for Manhole Rings AG

Two separate hydraulic circuits are needed on the side of the fork lift truck.

- Makes the production of manhole rings more efficient, as the rings and cones are gripped and lifted and set up hydraulically.
- As no radial pressure is exerted on the rings, green products can be safely handled.
- The setting up device can be used to transport and lift rings and cones.

| Type | Diameter Nominal Diameter mm (in) | Dead Weight kg (lbs) | Hydraulic Connection Pressure bar (psi) | Working Load Limit/WLL kg (lbs) | Order-Number |
|-------------|--------------------------------------|-------------------------|--|------------------------------------|-----------------|
| AG | 500 – 1,200 (19.69 – 47.24) | 425 (937) | 180 – 210 (2,611 – 3,046) | 1,500 (3,307) | 57200042 |
| AG-S | 625 – 1,200 (24.61 – 47.24) | 680 (1,499) | 180 – 210 (2,611 – 3,046) | 2,000 (4,409) | 57200043 |



RKZ-H

Ring- and Cone Clamp RKZ-H

A hydraulic grab attachment for transporting up to 3 manhole rings with a height of 500 mm (19.68 inch).

An adjustment to the widths is done hydraulically prior to the clamping action. This hydraulic change-over means that to operate the clamping and diameter setting action, only one hydraulic circuit is needed on the side of the fork lift truck.

The RKZ-HS is a heavy-duty model for up to 4 manhole rings with a height of 500 mm (19.68 inch). Supplied without connecting hoses to the fork lift truck.

If possible the Ring- and Cone Clamp RKZ-H/HS should be fitted onto the fork lift truck with a crane boom and a hydraulic rotator.

- Can also be used for single manhole cones due to its swinging grippers.
- Ideal for clearing the manufacturing area and for loading trucks.
- By clamping onto the walls of the products no radial pressure is exerted on the rings and so fairly green products can be removed from the manufacturing surface at a much earlier stage.

| Type | Diameter Nominal Diameter mm (in) | Inside Height mm (in) | Dead Weight kg (lbs) | Hydraulic Connection Pressure bar (psi) | Clamping Range mm (in) | Working Load Limit/WLL kg (lbs) | Order-Number |
|--------|-----------------------------------|-----------------------|----------------------|---|---------------------------|---------------------------------|--------------|
| RKZ-H | 600 – 1,500 (23.62 – 59.06) | 1,500 (59.06) | 680 (1,499) | 180 – 210 (2,611 – 3,046) | 50 – 150 (1.97 – 5.91) | 1,750 (3,858) | 57200011 |
| RKZ-HS | 600 – 1,500 (23.62 – 59.06) | 2,000 (78.74) | 790 (1,742) | 180 – 210 (2,611 – 3,046) | 50 – 150 (1.97 – 5.91) | 2,300 (5,071) | 57200012 |



RKG

Ring- and Cone Clamp RKG

Hydraulically operated universal grab attachment for manhole rings and cones.

Using only one hydraulic circuit the clamp firstly adjusts to the inner diameter and then clamps the ring wall by 3 hydraulically operated rubber-lined gripping claws.

Supplied without connecting hoses to the fork lift truck.

If possible, the Ring- and Cone Clamp RKG should be attached to the fork lift truck with a crane boom and a hydraulic rotator.

- As no radial pressure is exerted, it is possible to handle green products.
- Suitable for use with fork lift trucks as well as loading cranes.

| Type | Diameter Nominal Diameter mm (in) | Dead Weight kg (lbs) | Hydraulic Connection Pressure bar (psi) | Working Load Limit/WLL kg (lbs) | Order-Number |
|----------|-----------------------------------|----------------------|---|---------------------------------|--------------|
| RKG-25 | 600 – 2,500 (23.62 – 98.43) | 620 (1,367) | 180 – 210 (2,611 – 3,046) | 2,500 (5,512) | 57200187 |
| RKG-S-25 | 600 – 2,500 (23.62 – 98.43) | 655 (1,444) | 180 – 210 (2,611 – 3,046) | 4,000 (8,818) | 57200110 |
| RKG-S-30 | 600 – 3,000 (23.62 – 118.11) | 820 (1,808) | 180 – 210 (2,611 – 3,046) | 3,000 (6,614) | 57200094 |



Turning Device for Concrete Bases WG/WG-S

Enables concrete products such as manhole-basers to be turned around 180° after production (turning range 360° endless).

Supplied without connecting hoses to the fork lift truck.

- Because the products are turned at the longitudinal axle of the fork lift, there is very little extension so that the centre of gravity of the load and the device are very close to the fork lift.
- Both, the gripping and turning manoeuvres are fully hydraulic.
- Grippers lined with rubber metal bars and double-hinged so that they fit the various diameters well.
- Suitable for both round and square products.

WG

| Type | Diameter outside mm (in) | Dead Weight kg (lbs) | Height Stone/Element mm (in) | Hydraulic Connection Pressure bar (psi) | Working Load Limit/WLL kg (lbs) | Angle Pivoting-/Rotation Angle °Degree | Order-Number |
|-------------|----------------------------------|----------------------|------------------------------|---|---------------------------------|--|-----------------|
| WG | 900 – 1,580 (35.43 – 62.20) | 1,500 (3,307) | 900 (35.43) | 180 – 210 (2,611 – 3,046) | 3,000 (6,614) | 360 | 57200165 |
| WG-S | 1,200 – 2,200 (47.24 – 86.61) | 1,900 (4,189) | 900 (35.43) | 180 – 210 (2,611 – 3,046) | 4,500 (9,921) | 360 | 57200169 |



Gantry Crane – Rotating Clamp for Manhole Rings and Basers PWG-S

Hydraulic clamp, suitable to lift and rotate large concrete manhole rings and basers by 180°.

The grippers are specially adapted for manhole rings and basers, 2 opposite surfaces without an inlet or outlet are needed.

PWG-S

| Type | Length of Gripper mm (in) | Diameter outside mm (in) | Inside Height mm (in) | Electric Voltage / AC (50 Hz) V | Dead Weight kg (lbs) | Working Load Limit/WLL kg (lbs) | Angle Pivoting-/Rotation Angle °Degree | Order-Number |
|------------------|---------------------------|----------------------------------|-----------------------|---------------------------------|----------------------|---------------------------------|--|-----------------|
| PWG-S-4.5 | 650 (25.59) | 1,200 – 1,800 (47.24 – 70.87) | 1,300 (51.18) | 400 | 1,800 (3,968) | 4,500 (9,921) | 180 | 57400016 |
| PWG-S-8 | 800 (31½) | 940 – 1,800 (37.01 – 70.87) | 1,400 (55.12) | 400 | 3,144 (6,931) | 8,000 (17,637) | 180 | 57450015 |

011223 Technical data contained in this catalogue can be modified without prior notice in the interest of progress. Illustrations are exemplary and non-binding. No liability accepted for any misprints, mistakes and errors.



Steel Pallet Grab UMG

For lifting stacks of steel pallets and loading them into the magazine of the manhole manufacturing machine. Universally adjustable.

- Fully mechanical operation.
- Crane eye for attaching to crane hook.
- Fully automatic change over from “full” to “empty”.

UMG

| Type | Number of Claws Pcs. | Diameter Nominal Diameter mm (in) | Inside Height mm (in) | Dead Weight kg (lbs) | Working Load Limit/WLL kg (lbs) | Order-Number |
|--------------------|----------------------|--------------------------------------|--------------------------|-------------------------|------------------------------------|-----------------|
| UMG-30/80 | 3 | 300 – 800 (11.81 – 31.49) | 1,200 (47.24) | 90 (198) | 1,000 (2,205) | 57200051 |
| UMG-60/150 | 3 | 600 – 1,500 (23.62 – 59.06) | 1,200 (47.24) | 150 (331) | 1,500 (3,307) | 57200050 |
| UMG-150/300 | 3 | 1,500 – 3,000 (59.06 – 118.11) | 1,200 (47.24) | 290 (639) | 2,000 (4,409) | 57200063 |



Turning Device for Concrete Pipes UG

Supplied without connecting hoses to the fork lift truck.

- Makes the handling of concrete pipes after production far more efficient.
- Due to large surfaced pressure pads, little pressure is exerted onto the pipe, meaning that green products can be safely handled.
- As the pipes are turned in a raised position, there is no danger of damaging the joints or the steel pallets.
- The parallel movement of the gripping arms means little space is required between the pipes.

UG

| Type | Diameter Nominal Diameter mm (in) | Diameter outside mm (in) | Dead Weight kg (lbs) | Hydraulic Connection Pressure bar (psi) | Working Load Limit/WLL kg (lbs) | Order-Number |
|---------------|--------------------------------------|--------------------------------|----------------------|--|------------------------------------|-----------------|
| UG-3.5 | 300 – 1,000 (11.81 – 39.37) | 380 – 1,320 (14.96 – 51.97) | 820 (1,808) | 180 – 210 (2,611 – 3,046) | 3,500 (7,716) | 57300004 |
| UG-4.5 | 300 – 1,200 (11.81 – 47.24) | 400 – 1,580 (15.74 – 62.20) | 1,200 (2,646) | 180 – 210 (2,611 – 3,046) | 4,500 (9,921) | 57300025 |
| UG-6.5 | 300 – 1,500 (11.81 – 59.06) | 400 – 1,800 (15.74 – 70.87) | 1,970 (4,343) | 180 – 210 (2,611 – 3,046) | 6,500 (14,330) | 57300030 |



Rotating Clamp for Concrete Pipes WG-R

A novel method for rotation of several pipes in one operational sequence, regardless of accuracy of individual pipes interspace.

Length of rubber grippers L = 1,650 mm (65 inch).

Supplied without connecting hose to the fork-lift-truck.

- The clamp attachment enables the rotating of the pipes by $\pm 90^\circ$ (rotating range 360° endless) – without shunting the forklift.
- It is possible to pick up 3 pipes.

WG-R

| Type | Length of Gripper mm (in) | Diameter outside mm (in) | Dead Weight kg (lbs) | Hydraulic Connection Pressure bar (psi) | Working Load Limit/WLL kg (lbs) | Order-Number |
|--------------|------------------------------|--------------------------------|-------------------------|--|------------------------------------|-----------------|
| WG-R | 1,650 (64.96) | 300 – 1,300 (11.81 – 51.18) | 1,400 (3,086) | 180 – 210 (2,611 – 3,046) | 3,000 (6,614) | 57300044 |
| WG-SR | 2,000 (78.74) | 300 – 1,300 (11.81 – 51.18) | 1,700 (3,748) | 180 – 210 (2,611 – 3,046) | 4,500 (9,921) | 57300051 |



Small Pipe Turning Device FUG

2 separate hydraulic circuits are needed on the side of the fork lift truck.

Supplied without connecting cables to the fork lift truck.

- Makes the handling of small pipes after production more efficient.
- Up to 5 small pipes with a length of 1 m can be gripped at once.
- There is a manual adjustment to accommodate other widths. The pipes are grabbed from production vertically and can be stored horizontally due to the integrated swivel mechanism.
- As the pipes are gripped on their walls, no radial pressure is exerted on them, meaning that green products can be safely handled.

FUG

| Type | Description | Number of Pipes Pcs. | Dead Weight kg (lbs) | Hydraulic Connection Pressure bar (psi) | Working Load Limit/ WLL kg (lbs) | Order-Number |
|------------|--|----------------------|-------------------------|--|-------------------------------------|-----------------|
| FUG | up to 5 pipes with a width of 300 mm (113/4") | 5 | 450 (992) | 180 – 210 (2,611 – 3,046) | 1,500 (3,307) | 57300006 |



MFD

Multiple Forks MFD

For picking up several concrete pipes at the same time.

The device is lifted using the fork lift truck forks, with a lockpin on the forks. Distance between the bells of the pipes: 20 mm (0.78 inch). On request additional price for plastic lining of forks to protect the pipes.

- The spreader bar is lined with rubber so that the pipes cannot be damaged.
- Ideal for stacking the storage area and for loading trucks.

| Type | Number of Pipes Pcs. | Diameter Nominal Diameter mm (in) | Dead Weight kg (lbs) | Hydraulic Connection Pressure bar (psi) | Length Stone/Element mm (in) | Working Load Limit/ WLL kg (lbs) | Order-Number |
|----------|----------------------|-----------------------------------|----------------------|---|--------------------------------|----------------------------------|--------------|
| MFD-25-5 | 5 | 250 (9.84) | 300 (661) | | 2,000 – 3,000 (78.74 – 118.11) | 2,600 (5,732) | 57400001 |
| MFD-30-5 | 5 | 300 (11.81) | 330 (728) | | 2,000 – 3,000 (78.74 – 118.11) | 2,000 (4,409) | 57400085 |
| MFD-40-4 | 4 | 400 (15¾) | 350 (772) | | 2,000 – 3,000 (78.74 – 118.11) | 2,200 (4,850) | 57400086 |
| MFD-50-3 | 3 | 500 (19.69) | 375 (827) | | 2,000 – 3,000 (78.74 – 118.11) | 2,500 (5,512) | 57400104 |
| MFD-60-3 | 3 | 600 (23.62) | 400 (882) | | 2,000 – 3,000 (78.74 – 118.11) | 4,300 (9,480) | 57400026 |
| MFD-UNI | 5 | 300 – 600 (11.81 – 23.62) | 1,200 (2,646) | 180 – 210 (2,611 – 3,046) | 2,000 – 3,000 (78.74 – 118.11) | 5,000 (11,023) | 57400067 |



RK

Manhole Ring Clamp RK-XL-IV/-V/-VI

With the mechanical large pipe clamp, concrete pipes up to ID 2800 mm (110 inch) can be safely grabbed vertically after production and placed on a tilting table.

- Fully mechanical operation, making it suitable for use with any lifting equipment.
- Adjustable to the dimensions of the pipe in a hand crank.
- Crane eye for attaching to crane hook.
- Fully automatic change-over from “full” to “empty”, making it an absolute one-man machine.

| Type | Number of Claws Pcs. | Diameter Nominal Diameter mm (in) | Inside Height mm (in) | Dead Weight kg (lbs) | Gripping Range mm (in) | Working Load Limit/ WLL kg (lbs) | Order-Number |
|----------|----------------------|-----------------------------------|-----------------------|----------------------|--------------------------|----------------------------------|--------------|
| RK-XL-IV | 2 | 1,000 – 1,800 (39.37 – 70.87) | 750 (29.53) | 600 (1,323) | 110 – 240 (4.33 – 9.45) | 7,500 (16,535) | 57300001 |
| RK-XL-V | 2 | 1,500 – 2,600 (59.06 – 102.36) | 1,000 (39.37) | 1,700 (3,748) | 110 – 280 (4.33 – 11.02) | 15,000 (33,069) | 57300002 |
| RK-XL-VI | 2 | 1,500 – 2,800 (59.06 – 110.24) | 1,000 (39.37) | 2,680 (5,908) | 100 – 300 (3.94 – 11.81) | 25,000 (55,116) | 57300009 |



Tilting Table KT

Using the Large Pipe RK, the concrete pipes up to 3 m (118 inch) in length are placed on the tilting table. Then the pipes are tilted hydraulically by 90°. The pipes, now lying flat, are then removed by a forklift truck or crane.

Electro-hydraulically operated tilting table.

Tilting table equipped with fork sleeves for fork lift trucks so that the whole device can be moved easily.

KT

| Type | Width mm (in) | Dead Weight kg (lbs) | Working Load Limit/WLL kg (lbs) | Order-Number |
|-------|----------------|----------------------|---------------------------------|--------------|
| KT-15 | 3,450 (135.83) | 6,000 (13,228) | 15,000 (33,069) | 57400008 |
| KT-25 | 3,600 (141.73) | 15,000 (33,069) | 25,000 (55,116) | 57400007 |



Gantry Crane Rotating Clamp for Concrete Pipes PWG-R

A special hydraulic clamp designed to lift and rotate large concrete pipes by 90°.

Hydraulically powered by means of an electro hydraulic pump unit.

Incl. electric installation, connection 400 V/50 Hz.

- Space saving use on gantry crane.
- Fully hydraulic clamp, adjustable to various diameters.
- Large surface pressure pads with swinging rubber grippers ensure a good pressure distribution all over and so enable the production area to be cleared more quickly.
- The parallel movement of the gripping arms means that little space is required between the pipes.

PWG-R

| Type | Length of Gripper mm (in) | Working Pressure bar (psi) | Diameter outside mm (in) | Inside Height mm (in) | Dead Weight kg (lbs) | Working Load Limit/WLL kg (lbs) | Angle Pivoting-/Rotation Angle °Degree | Order-Number |
|----------|---------------------------|----------------------------|-----------------------------------|-----------------------|----------------------|---------------------------------|--|--------------|
| PWG-R-3 | 500 (19.69) | 210 (3,046) | 400 – 1,200 (15.74 – 47.24) | 1,600 (62.99) | 1,500 (3,307) | 3,000 (6,614) | 100 | 57450004 |
| PWG-R-7 | 900 (35.43) | 210 (3,046) | 400 – 1,880 (15.74 – 74.02) | 2,050 (80.71) | 3,150 (6,945) | 7,000 (15,432) | 100 | 57450006 |
| PWG-R-13 | 1,360 (53.54) | 210 (3,046) | 1,080 – 2,750 (42.52 – 108.27) | 2,190 (86.22) | 9,200 (20,283) | 13,000 (28,660) | 100 | 57450008 |
| PWG-R-20 | 1,500 (59.06) | 210 (3,046) | 1,800 – 3,550 (70.87 – 139.76) | 2,350 (92.52) | 15,000 (33,069) | 20,000 (44,092) | 100 | 57450007 |

011223 Technical data contained in this catalogue can be modified without prior notice in the interest of progress. Illustrations are exemplary and non-binding. No liability accepted for any misprints, mistakes and errors.



Fork Lift Grab STAZ-KS

Specially designed for operation in silicate block factories.

With crane boom, hydraulic continuous rotator, hydraulic swing damper and rubber grippers for handling silicate blocks gently.

Different models to cope with specific needs available on request.

- Working load limit up to 6,000 kg (13,228 lbs).
- Plastic sliding guides come with a 5 year guarantee.

| Type | Order-Number |
|---------|--------------|
| STAZ-KS | On Request |

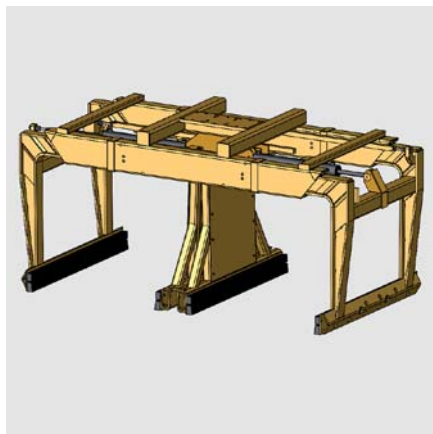

Double Fork Lift Grab STAZ-DZ-I

The same characteristics as the STAZ-UNI but, due to an additional hydraulically spreadable centre divider it can be used to lift 2 stacks at the same time if they are standing across on the conveyor belt.

Supplied without connecting hoses to the fork lift-truck.

- The extremely slim build of the central divider (200 mm/7¾ inch closed, 300 mm/11¾ inch spreaded) means a lot of space can be saved when stacking goods.
- Only one hydraulic circuit is needed to be supplied by the fork lift truck to operate both, clamping and center divider due to a hydraulic sequence circuit.
- Plastic sliding guides come with a 5 year guarantee.
- Larger or modified opening widths and heights are available on request.

STAZ-DZ-I

| Type | Inside Height mm (in) | Dead Weight kg (lbs) | Hydraulic Connection Pressure bar (psi) | Opening Width Main Gripper mm (in) | Working Load Limit/ WLL kg (lbs) | Gripper Base Length Main Gripper mm (in) | Order-Number |
|----------------|--------------------------|-------------------------|--|---------------------------------------|-------------------------------------|--|--------------|
| STAZ-DZ-I-850 | 850 (33.46) | 900 (1,984) | 180 – 210 (2,611 – 3,046) | 710 – 1,100 (27.95 – 43.31) | 4,400 (9,700) | 1,250 (49.21) | 57000164 |
| STAZ-DZ-I-1000 | 1,000 (39.37) | 960 (2,116) | 180 – 210 (2,611 – 3,046) | 550 – 1,100 (21.65 – 43.31) | 4,400 (9,700) | 1,250 (49.21) | 57000170 |

011223 Technical data contained in this catalogue can be modified without prior notice in the interest of progress. Illustrations are exemplary and non-binding. No liability accepted for any misprints, mistakes and errors.



STAZ-UNI-P



STAZ-UNI-KA

Fork Lift Grab STAZ-UNI-P/STAZ-UNI-KA

Specially designed for the heavy duty work with forklift truck, directly fixed to the carriage plate of the forklift.

We recommend the use of a side-shift built into the forklift.
Supplied without connecting hoses to the forklift-truck.

- Light-weight, yet with a high working load limit due to the use of high-tensile steel for load bearing parts.
- Can fit all the usual packs of building materials due to a large opening range and to the exchangeable grippers which come in various lengths and designs. Fully hydraulic parallel opening range.
- Low maintenance steel plastic sliding guides.
- Manually adjustable pressure relieve valve.
- Oil Pressure Gauge.
- Plastic sliding guides come with a 5 year guarantee.
- Larger or modified opening widths and heights are available on request.

At **STAZ-UNI-P-1000**: grips the pack by pressing it towards the gripper close to the forklift. This achieves smallest possible load center of the pack.

At **STAZ-UNI-KA-1000**: moves both grippers synchronized towards the pack. Compact design due to integrated crane boom.

| Type | Inside Height mm (in) | Dead Weight kg (lbs) | Hydraulic Connection Pressure bar (psi) | Opening Width Main Gripper mm (in) | Working Load Limit/WLL kg (lbs) | Order-Number |
|-------------------------|--------------------------|-------------------------|--|---------------------------------------|------------------------------------|-----------------|
| STAZ-UNI-P-1000 | 1,000 (39.37) | 440 (970) | 180 – 210 (2,611 – 3,046) | 580 – 1,260 (22.83 – 49.61) | 2,300 (5,071) | 57000087 |
| STAZ-UNI-KA-1000 | 1,000 (39.37) | 690 (1,521) | 180 – 210 (2,611 – 3,046) | 370 – 1,370 (14.57 – 53.94) | 2,000 (4,409) | 57000173 |



ASZ

Sorting Clamp ASZ

This universal outsourcing clamp has a wide adjustable opening width and can be used for a wide range of products.

There are two different variations:

1. ASZ for the efficient outsourcing of concrete steps, kerb stones and similar.
2. ASZ-R for the handling of sewerage elements. The grippers are prism-shaped to grip the round contour of the rings.

Please note: Designed and suitable to grip single stones or elements only. This is not the proper equipment for handling a complete row of stones.

- Lifting eye for attaching to crane hook.
- Lifting handle.
- Handle with turning range 90° depending on space.
- Exchangeable rubber metal bars, to suit the requirements.
- Automatic release for fully automatic switch-over from "full" to "empty".

| Type | Length of Gripper mm (in) | Diameter outside mm (in) | Inside Height mm (in) | Dead Weight kg (lbs) | Gripping Range mm (in) | Working Load Limit/WLL kg (lbs) | Order-Number |
|-------|------------------------------|--------------------------------|--------------------------|-------------------------|--------------------------------|------------------------------------|--------------|
| ASZ | 200 (7.87) | | 120 (4.72) | 26 (57) | 600 – 1,200 (23.62 – 47.24) | 250 (551) | 53100259-005 |
| A-50 | 50 (1.97) | | | 1.3 (2.87) | | | 43100376 |
| A-100 | 100 (3.94) | | | 0.8 (1.76) | | | 43100377 |
| ASZ-R | 300 (11.81) | 600 – 1,200 (23.62 – 47.24) | 100 (3.94) | 34 (75) | | 250 (551) | 53100281-003 |



Pneumatic Rotating Clamp P-WG

For rotation by 90° or 180° of concrete products as for example slabs, side-angles, kerb stones.

Pneumatic clamping and rotating around the longitudinal axis.

- Lifting eye for attaching to crane hook.
- Pneumatic closing cylinder and additional manual adjustment for a larger opening width.
- Manual-controlled valves for clamping and rotating at the guide handle.
- Grippers coated with exchangeable rubbers.

P-WG

| Type | Compressed Air Connection Pressure bar (psi) | Inside Height mm (in) | Dead Weight kg (lbs) | Opening Width Main Gripper mm (in) | Working Load Limit/ WLL kg (lbs) | Angle Pivoting-/ Rotation Angle ° Degree | Order-Number |
|------|---|--------------------------|-------------------------|---------------------------------------|-------------------------------------|--|--------------|
| P-WG | 6 – 10 (87.02 – 145.04) | 285 (11.22) | 200 (441) | 600 – 2,000 (23.62 – 78.74) | 500 (1,102) | 180 | 57400109 |



Pneumatic Sorting Clamp ASZ-P

This universal outsourcing clamp offers a versatile use due to large adjustable opening width. Optimum for slabs, kerb stones and wall-rings for plants, etc.

Suitable for attachment to a vacuum lifting unit or to a overhead or jib crane.

Cylinder lifting 150 mm (6 inch): the further range of opening width is mechanically adjustable.

- With flange plate to attach to a vacuum lifting unit, alternatively with a lifting eye.
- With pneumatic closing cylinder and additional manual adjustment to achieve a larger opening width.
- Hand-guided valve with closing cylinder.
- Other opening widths and heights are available on request.

ASZ-P

| Type | Compressed Air Connection Pressure bar (psi) | Dead Weight kg (lbs) | Opening Width Main Gripper mm (in) | Working Load Limit/WLL kg (lbs) | Order-Number |
|-------|---|-------------------------|---------------------------------------|------------------------------------|--------------|
| ASZ-P | 6 – 10 (87.02 – 145.04) | 32 (71) | 220 – 1,050 (8.66 – 41.34) | 120 (265) | 57400023 |

011223 Technical data contained in this catalogue can be modified without prior notice in the interest of progress. Illustrations are exemplary and non-binding. No liability accepted for any misprints, mistakes and errors.



VAH-12

Vacuum Sorting Lifter VAH-12

The vacuum sorting aid enables simple and fast sorting, palletising and moving of smaller slabs and paving stones with one hand.

- Suction plate made from lightweight aluminium.
- The VAH-12 can even be connected to standard industrial vacuum cleaners (wet/dry vacuum cleaner with bypass valve for permanent cooling) by means of the supplied connection cones. It is recommended to use the VGE-SB-L-E vacuum fan unit for uninterrupted operation.
- Easy, precise handling and fast cycle times.
- Ensures an ideal reduction of workload and increased productivity.

Scope of delivery:

VAH-12: 1 x single-handed suction plate with handle, 1 x lifting hose (Ø 80 mm), 2 x connecting cone for industrial vacuum cleaners, 1 x adapter for turbine unit VGE-SB-L-E.

| Type | Dimensions L x W x H mm (in) | Dead Weight kg (lbs) | Working Load Limit/WLL kg (lbs) | Order-Number |
|---------------|--|----------------------|---------------------------------|-----------------|
| VAH-12 | 200 x 95 x 160 (7.87 x 3.74 x 6.30) | 8 (18) | 12 (26) | 58500008 |



VACUSPEED VXS

VACUSPEED VXS Vacuum-Hose-Lifter

The VACUSPEED VXS vacuum hose lifter ensures best ease of working combined with highest productivity when handling pavers, slabs etc. Ideal for quality control work! For connecting vacuum pump unit to the lifting unit.

- The vacuum energy is used for holding the material as well as for lifting and lowering it.
- Can be operated easily, exactly and quickly. No manual lifting force necessary.
- Precise one hand operation, suitable for left- and right-hander.
- Dense/not porous materials of all types and weight up to max. 35 kg (75 lbs) or 50 kg (110 lbs) can be easily lifted, sorted, packed or laid.
- Advantage: No need to get access sideways to the products to be sorted for gripping, Access from the top is fully sufficient!
- High lifting speed of up to 50 m/min (54.7 ft/min).
- Lifting and lowering speed is continuously.
- Suction plate can swivel by 90 degrees in order to pick up and handle products vertically.
- With quick change system for different suction plates (SPS).
- Suction plate see chart.
- The VACUSPEED VXS-35-P and 50-P can be suspended to any crane system within seconds and is ready to work.
- With electrical glanded pump for vacuum generation.

Scope of delivery:

VXS-35-P/VXS-50-P: Electricity driven vacuum pump, motor protection switch, dust filter, lifting unit and operating unit without suction plate and quick-change device for suction plate.

| Type | Type of Drive electric/AC (50 Hz) kW | Type of Drive electric/AC (60 Hz) kW | Electric Voltage / AC (60 Hz) V | Electric Voltage / AC (50 Hz) V | Dead Weight kg (lbs) | Height Lifting Height mm (in) | Working Load Limit/WLL kg (lbs) | Order-Number |
|----------|--------------------------------------|--------------------------------------|---------------------------------|---------------------------------|----------------------|-------------------------------|---------------------------------|--------------|
| VXS-35-P | 1.25 | 1.5 | 240/480 | 230/400 | 47 (104) | 1,500 (59.06) | 35 (77) | 57600034 |
| VXS-50-P | 2.4 | 3 | 240/480 | 230/400 | 82 (181) | 1,500 (59.06) | 50 (110) | 57600041 |

Accessories:

| Type | Description | Dimensions L x W mm (in) | Diameter inside mm (in) | Dead Weight kg (lbs) | Working Load Limit/WLL -600 mbar kg (lbs) | Order-Number |
|------------------------------------|-------------|--------------------------|-------------------------|----------------------|---|--------------|
| VXS-SPS-35 | | 175 x 175 (6.89 x 6.89) | | 0.87 (1.92) | 35 (77) | 47610026 |
| VXS-SPS-35 | | 240 x 160 (9.45 x 6.30) | | 0.85 (1.87) | 35 (77) | 47610022 |
| VXS-SPS-50 | | 194 x 194 (7.64 x 7.64) | | 0.8 (1.76) | 50 (110) | 47610024 |
| Supply Hose for VXS-35-P | Cut goods | | 25 (0.98) | | | 47610008 |
| Supply Hose for VXS-50-P | Cut goods | | 32 (1.26) | | | 25200011 |
| Dust filter cartridge for VXS-35-P | | | | 0.08 (0.18) | | 42500120 |
| Dust filter cartridge for VXS-50-P | | | | 0.2 (0.44) | | 25000027 |

Aluminium Smooth Running Cranes for VACUSPEED VXS

The Probst aluminum wall and pillar swing cranes are particularly designed for operation with vacuum hose lifter VACUSPEED VXS.

The vacuum hose lifters eliminate the manual lifting job completely, but swinging the crane arm around or pulling the suspension along the jib can be very burdening when using standard heavy crane systems.

The new aluminium crane systems of Probst are now offering ergonomically advantages by smooth running and lightweight design.



Pillar Swing Crane VXS-ASSK-65-4

Same specifications as Wall Swing Crane AWSK, but slewing range 270°, length and working load limit see table.

Important notice: The assumption for mounting the pillar swing crane using the set of dowels is minimum thickness of the concrete floor of 200 mm (73/4") and a concrete quality C20/25. (Simple installation, no flange plates needed).

Optional accessories: Set of dowels DS-ASSK, consisting of the following components:

Special Anchor with mortar cartridge and bushes, 8 times threaded M 12, thickness of plate min. 8 mm (1/3") max 25 mm (1").

VXS-ASSK-65-4

| Type | Load Extension mm (in) | Dead Weight kg (lbs) | Working Load Limit/WLL kg (lbs) | Angle Pivoting-/Rotation Angle °Degree | Order-Number |
|---------------|---------------------------|-------------------------|------------------------------------|---|--------------|
| VXS-ASSK-65-4 | 4,000 (157.48) | 155 (342) | 65 (143) | 270 | 42000137 |

Accessories:

| Type | Description | Dead Weight kg (lbs) | Order-Number |
|------------------|-------------------------------------|----------------------|--------------|
| VXS-ASSK-KP-65-4 | For crane 65 kg, reach 4m | 1,130 (2,491) | 42000157 |
| DS-ASSK | Set of dowel for pillar swing crane | 2.5 (5.51) | 42000100 |



VXS-AWSK-65-4

Wall Swing Crane VXS-AWSK-65-4

The static for fixing the crane to the wall has to be checked by the customer.
CE approved.

- The equal load distribution of the rollers of roller suspension eliminates cocking of the suspension, even when pulled sideways.
- Special bearings of the swinging arm and the use of lightweight aluminium are ensuring easy and smooth operation.
- Special, long lasting rollers.
- Modern design.
- Innovative geometrie of the jib profile.
- Adjustable stops to restrict the the movement along the jib if required.
- Slewing range 180°.
- Optimized height of the jib.

Scope of delivery

VXS-AWSK-65-4: Comes with adjustable stop, carrier for pipe or cable, roller suspension for hose lifter.

| Type | Load Extension mm (in) | Dead Weight kg (lbs) | Working Load Limit/WLL kg (lbs) | Angle Pivoting-/Rotation Angle °Degree | Order-Number |
|----------------------|---------------------------|-------------------------|------------------------------------|---|-----------------|
| VXS-AWSK-65-4 | 4,000 (157.48) | 77 (170) | 65 (143) | 180 | 42000138 |

Vacuum Hose Lifter for In-Plant Use

Probst offers a wide range of solutions for in-plant use.



JWK-80/250-4-EU

Jumbo Travelling Crane JWK

Complete ready-to-use unit comprising crane, ballast, electrics and vacuum turbine. Complete with socket.

Ballast container, made of steel sheet, approx. 1.0 x 0.8 x 1.8 m height (40" x 31 1/2" x 71") should be filled with concrete, sand or steel scrap. Thus ensuring the necessary stability.

Adjusting screws for alignment.

Light weight boom, 4,000/5,000 mm (157.48/196.85 inch) reach, height adjustable and with a displacement of about 270°.

Supply-hose D = 60 mm (2.6 inch), 7,000 mm (275.59 inch) long. With quick coupling 2 inch.

To complete your Jumbo Travelling Crane JWK you need: Lifting Unit, Operating Valve Unit, Suction Plate.

- The machine can be moved easily by taking up with the fork prongs.
- Various lifting units and grippers can be attached to the Jumbo Travelling Crane JWK (see specifications).
- The lifting and lowering speed can be controlled extremely smoothly.
- Can be operated easily, exactly and quickly.
- Materials of all types can be easily lifted, sorted and layed.
- The vacuum is used for holding the materials as well as for lifting them.
- Efficient working practices and less stress on your workers.

Scope of delivery:

JWK: Vacuum turbine VGE-SB-EL with electric motor (electrical date see page 50), incl. pressure regulating valve DBV, motor protector switch and socket "CEKON" 32 A with integral phase switch, dust-filter with pre-separator and filter cartridge.

| Type | Load Extension mm (in) | Weight Counter Weight/ Ballast kg (lbs) | Dead Weight kg (lbs) | Working Load Limit/WLL kg (lbs) | Order-Number |
|-----------------|---------------------------|--|-------------------------|------------------------------------|--------------|
| JWK-80/250-4-EU | 4,000 (157.48) | 3,600 (7,937) | 1,050 (2,315) | 250 (551) | 52800019 |
| JWK-80/250-5-EU | 5,000 (196.85) | 4,600 (10,141) | 1,110 (2,447) | 250 (551) | 52800021 |

13



Lifting Hose Units HE

For use with the JUMBOMOBIL JM, JUMBO-BV, TRANSMOBIL TM, JUMBO Travelling Crane JWK or on any other crane carrier.

(Application of lifting hose unit HE-250 is not to be operated and JUMBOMOBIL).

Consists of:

Transportation hook.

Rotational Device and quick coupling, 2 inch.

Lifting hose unit with protective fabric as well as a flange for fitting onto the operating valve unit.

Available optionally for HE-150/200/250: reinforced belt stay with buckle.

HE-35 – HE-250

| Type | Diameter outside mm (in) | Dead Weight kg (lbs) | Height Lifting Height mm (in) | Working Load Limit/WLL -420 mbar kg (lbs) | Order-Number |
|--------|--------------------------|----------------------|-------------------------------|---|--------------|
| HE-35 | 120 (4.72) | 9.5 (21) | 1,700 (66.93) | 35 (77) | 42100001 |
| HE-50 | 140 (5.51) | 10.5 (23) | 1,700 (66.93) | 50 (110) | 42100106 |
| HE-85 | 178 (7.01) | 13.5 (30) | 1,700 (66.93) | 85 (187) | 42100002 |
| HE-150 | 230 (9.06) | 18.5 (41) | 1,500 (59.06) | 150 (331) | 42100132 |
| HE-200 | 250 (9.84) | 22.5 (50) | 1,500 (59.06) | 200 (441) | 42101114 |
| HE-250 | 300 (11.81) | 26.6 (59) | 1,500 (59.06) | 250 (551) | 42101115 |



Operating Valve Unit BE-SPRINT-2

For direct coupling onto the lifting unit HE.

Longer operating handles on request.

Scope of delivery

BE-SPRINT-2: Main body with handle 500 mm (19½ inch) long, fixing screw for adjusting the hovering position, safety gauge.

BE-SPRINT-2

| Type | Description | Dead Weight kg (lbs) | Order-Number |
|-------------|------------------------|----------------------|--------------|
| BE-SPRINT-2 | for HE-35 up to HE-250 | 8.5 (19) | 42100539 |



Ergonomic Vacuum Control Unit BE-ERGOSPRINT

Picking up and laying concrete elements in an upright posture.

The new ergonomic operating valve unit for mounting on all HE lifting units and vacuum hose lifters, including JUMBOMOBIL JM, TRANSMOBIL TM and JUMBO-BV.

- No more bending over when picking up, moving and laying the concrete element.
- Control of suction and release via rotary handle on the right handle.
- Handle can be locked in the uppermost position.
- Greater safety clearance to paving material.

BE-ERGOSPRINT

| Type | Description | Dead Weight kg (lbs) | Order-Number |
|----------------------|------------------------|----------------------|-----------------|
| BE-ERGOSPRINT | for HE-35 up to HE-250 | 13.5 (30) | 42101305 |



Hose Cylinder Extension SZV

Only to be used as and when required to enable ergonomic working conditions, at certain heights.

Length 300 mm (11.81 inch).

Scope of delivery

SZV: Vacuum pipe with quick fasteners and transmission bar for ram.

SZV

| Type | Description | Dead Weight kg (lbs) | Order-Number |
|----------------|-------------------------|----------------------|-----------------|
| SZV | for HE-35 up to HE-150 | 3.2 (7.05) | 42100007 |
| SZV-250 | for HE-200 up to HE-250 | 5.8 (13) | 42100008 |

011223 Technical data contained in this catalogue can be modified without prior notice in the interest of progress. Illustrations are exemplary and non-binding. No liability accepted for any misprints, mistakes and errors.

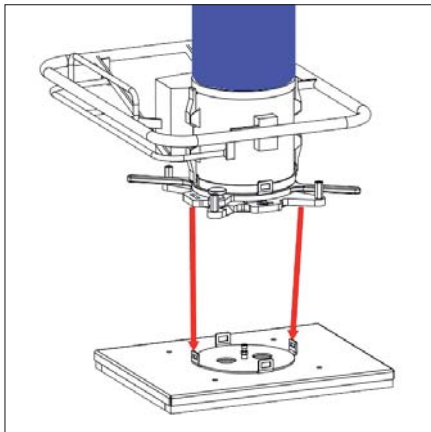

SWV-HE

Quick Change Device SWV-HE

Suction plates are usually fixed to the operating valve unit BE or hose cylinder extension SVZ through two hook latches.

In case suction plates have to be changed continually, the quick change device SWV-HE is highly recommended.

When using lifting hose units HE-200 and He-250, the lifting hose unit is fitted directly to the lifting hose unit by means of 4 tension rods (threaded rods).

- Faster suction plate changing with a simple twisting motion.
- Suitable for all lifting hose units from HE-35 to HE-250.
- Easy operation, no inconvenient screwing of adapters required.
- Operating errors no longer possible.

| Type | Description | Dead Weight kg (lbs) | Working Load Limit/WLL kg (lbs) | Order-Number |
|--------|---------------------|-------------------------|------------------------------------|--------------|
| SWV-HE | Quick change device | 3.8 (8.38) | 250 (551) | 42101026 |



ESP-150-31/31

Suction Plates ESP

For the direct coupling to the operating valve unit, the hose cylinder extension or quick-change device.

Suction plates with attached foam rubber seal, including lifter for tactile steering.

For more suction plates contact us for professional advice.

| Type | Dimensions L x W mm (in) | Dead Weight kg (lbs) | Working Load Limit/WLL -420 mbar kg (lbs) | Order-Number |
|-------------------|-----------------------------|-------------------------|--|--------------|
| ESP-35-20/20 | 200 x 200 (7.87 x 7.87) | 2 (4.41) | 35 (77) | 42100050 |
| ESP-50-23/23 | 230 x 230 (9.06 x 9.06) | 3 (6.61) | 50 (110) | 42100561 |
| ESP-85-25,5/25,5 | 255 x 255 (10.04 x 10.04) | 8 (18) | 85 (187) | 42100051 |
| ESP-150-31/31 | 310 x 310 (12.20 x 12.20) | 2.8 (6.17) | 150 (331) | 42100145 |
| ESP-150-40/27,5 | 400 x 275 (15¾ x 10.83) | 5 (11) | 150 (331) | 42100116 |
| ESP-150-50/19 | 500 x 190 (19.69 x 7.48) | 7 (15) | 150 (331) | 52300019 |
| ESP-150-92,4/13,4 | 924 x 134 (36.38 x 5.28) | 5 (11) | 150 (331) | 52300008 |
| ESP-150-100/12,4 | 1,000 x 124 (39.37 x 4.88) | 6 (13) | 150 (331) | 52300007 |
| ESP-200-33/33 | 330 x 330 (12.99 x 12.99) | 3 (6.61) | 200 (441) | 42100331 |
| ESP-250-40/40 | 400 x 400 (15¾ x 15¾) | 5 (11) | 250 (551) | 42100054 |

Please note: To ensure that the detachment safety device functions properly, suction plates with a lower load capacity than the lifting unit HE allows must not be used. The use of suction plates with a higher load capacity than that of the lifting unit is permitted.



Angled Suction Plates WSP

For direct coupling to the operating valve unit, hose cylinder extension or quick-change device.

Suction plates with attached foam rubber seal, including lifter for tactile steering. Other suction plates on request.

WSP

| Type | Dimensions L x W x H mm (in) | Dead Weight kg (lbs) | Working Load Limit/ WLL -420 mbar kg (lbs) | Angle °Degree | Order-Number |
|-----------------------|---------------------------------------|-------------------------|---|---------------|--------------|
| WSP-150-52/15-12-98° | 520 x 150 x 120 (20.47 x 5.91 x 4.72) | 4.7 (10) | 150 (331) | 98 | 52500184 |
| WSP-150-70/8-11-143° | 700 x 80 x 110 (27.56 x 3.15 x 4.33) | 6 (13) | 150 (331) | 143 | 42100238 |
| WSP-150-70/11-17-143° | 700 x 110 x 170 (27.56 x 4.33 x 6.69) | 6 (13) | 150 (331) | 143 | 42100126 |
| WSP-150-85/7-7-135° | 850 x 70 x 70 (33.46 x 2.76 x 2.76) | 6 (13) | 150 (331) | 135 | 52300018 |
| WSP-150-70/13-10-143° | 700 x 130 x 100 (27.56 x 5.12 x 3.94) | 6 (13) | 150 (331) | 143 | 52500131 |
| WSP-150-90/10-14-93° | 900 x 100 x 140 (35.43 x 3.94 x 5.51) | 7 (15) | 150 (331) | 93 | 52300033 |
| WSP-150-90/8-11-90° | 900 x 80 x 110 (35.43 x 3.15 x 4.33) | 7.5 (17) | 150 (331) | 90 | 42100795 |

Please note: To ensure that the detachment safety device functions properly, suction plates with a lower load capacity than the lifting unit HE allows must not be used. The use of suction plates with a higher load capacity than that of the lifting unit is permitted.



Multiple Suction Plate MSP-3-S-150-3x22Rd

Easy lifting and laying of concrete blocks.

With the 3-fold suction plate, concrete block paving can be laid effortlessly.

- Suitable for Probst lifting units up to HE-150.
- The distance between the suction plates can be adjusted with screws.
- Quickly replaceable sealing rings with low-wear sponge rubber.

MSP 3-way (rigid)

| Type | Dimensions oval, L x B mm (in) | Number of Suction Plates Pcs. | Dead Weight kg (lbs) | Working Load Limit/WLL -420 mbar kg (lbs) | Order-Number |
|--------------------|-----------------------------------|----------------------------------|-------------------------|--|--------------|
| MSP-3-S-150-3x22Rd | 220 (8.66) | 3 | 9.9 (22) | 150 (331) | 42101192 |

011223 Technical data contained in this catalogue can be modified without prior notice in the interest of progress. Illustrations are exemplary and non-binding. No liability accepted for any misprints, mistakes and errors.

NEW

Multiple Suction Plates MFS

Easy laying of up to 7 concrete blocks.

Attached to the various lifting units HE (up to HE-150), you can lay up to 7 concrete blocks safely and quickly with the Probst multiple suction plates MFS.

MFS-150-7-S-15Rd (rigid): Multiple suction plate (7 bellows) with various predefined hole spacings for mounting the bellows. It is also possible to lift only 5 or 6 bricks. Unused bellows can be plugged with an optionally available protective cover and sealing plate and mounted on top of the traverse for trouble-free operation.

MFS-85-6-S-15Rd (rigid): Multiple suction plate (6 bellows) with various predefined hole spacings for mounting the bellows. Only 4 or 5 bricks can also be lifted. Bellows that are not required can be sealed with an optionally available protective cover and sealing plate and attached to the top of the lifting beam for trouble-free operation.

MFS-150-4-S-20Rd (rigid): Multiple suction plate (4 bellows).

MFS-150-7-V-15Rd (movable): Multiple suction plate (7 bellows) with distance adjustment. DIN18318 (road construction work, paving and paving slabs) stipulates a distance between the individual stones, particularly when laying gutter stones. For this reason, a hand lever can be used to set a distance of 8 mm between the individual stones when the MFS is raised. For block length 160 mm.

MFS-150-5-V-15Rd (movable): Multiple suction plate (5 bellows) with adjustable spacing. DIN18318 (road construction work, paving and paving slabs) stipulates a distance between the individual stones, particularly when laying gutter stones. For this reason, a hand lever can be used on this MFS to set a distance of 8 mm between the individual stones when raised. For block length 240 mm.

- Height and angle compensation means that even rows of stones that are not completely level can be lifted.
- Fast suction process.
- Sealing bellows can be quickly replaced without tools.



MFS 7-way (rigid)



MFS 7-way (movable)

| Type | Dimensions oval, L x B mm (in) | Number of Suction Plates Pcs. | Dead Weight kg (lbs) | Working Load Limit/WLL -420 mbar kg (lbs) | Shifting mm (in) | Order-Number |
|-------------------------|--------------------------------|-------------------------------|----------------------|---|------------------|-----------------|
| MFS-85-6-S-15Rd | 150 x 150 (5.91 x 5.91) | 6 | 11,2 (24.64) | 85 (187) | | 42101510 |
| MFS-150-7-S-15Rd | 150 x 150 (5.91 x 5.91) | 7 | 12 (26) | 150 (331) | | 42101500 |
| MFS-150-4-S-20Rd | 200 x 200 (7.87 x 7.87) | 4 | 12 (26) | 150 (331) | | 42101535 |
| MFS-150-5-V-15Rd | 150 x 150 (5.91 x 5.91) | 5 | 14 (31) | 150 (331) | 8 (0.31) | 42101542 |
| MFS-150-7-V-15Rd | 150 x 150 (5.91 x 5.91) | 7 | 15 (33) | 150 (331) | 8 (0.31) | 42101501 |

Accessories:

| Type | Dimensions oval, L x B mm (in) | Dead Weight kg (lbs) | Order-Number |
|-------------------------|--------------------------------|----------------------|-----------------|
| Protective cover | 150 x 150 (5.91 x 5.91) | | 42101506 |
| Sealing plate | 145 x 145 (5.71 x 5.71) | 0.1 (0.22) | 33510026 |



top: UZ-BV, bottom: VZ-BV



RG-VZ

Mechanical clamps for lifting unit

Mechanical grippers can be mounted instead of vacuum suction plates onto the vacuum hose lifter.

In this scenario, the vacuum energy is lifting the products whilst the mechanical gripper grabs the product. In this case, the sensitive speed control of lifting and lowering by the vacuum hose lifter is obtained.

UZ-BV: universal kerb stone clamp specially designed to grab the kerbs crossway. This is how curved kerb stones with different radiuses can be handled.

VZ-BV-98/100: this clamp has been specially designed to cope with the rare cases when kerb stones are too porous to be lifted with vacuum, so they therefore have to be lifted mechanically.

VZ-BV-40/104: this clamp has been specially designed to cope with the rare cases when kerb stones are too porous to be lifted with vacuum, so they therefore have to be lifted mechanically.

RG-VZ: Special clamp for the laying of 1, 2 or 3 grass stone slabs in one movement.

| Type | Description | Length of Gripper mm (in) | Inside Height mm (in) | Dead Weight kg (lbs) | Gripping Range mm (in) | Working Load Limit/WLL kg (lbs) | Order-Number |
|---------------------|------------------------------|---------------------------|-----------------------|----------------------|--------------------------------|---------------------------------|-----------------|
| UZ-BV | Radius Kerb Clamp | 250 (9.84) | 214 (8.43) | 12 (26) | 80 – 220 (3.15 – 8.66) | 150 (331) | 52300031 |
| VZ-BV-98/100 | Mechanical Kerb Stone Handle | 100 (3.94) | 70 (2.76) | 8 (18) | 980 – 1,000 (38.58 – 39.37) | 150 (331) | 42300001 |
| VZ-BV-40/104 | Mechanical Kerb Stone Handle | 100 (3.94) | 55 (2.17) | 6.9 (15) | 400 – 1,045 (15¾ – 41.14) | 150 (331) | 42300149 |
| RG-VZ | Turf Stone Handle | 50 (1.97) | 80 (3.15) | 12 (26) | 100 – 490 (3.94 – 19.29) | 70 (154) | 42000003 |

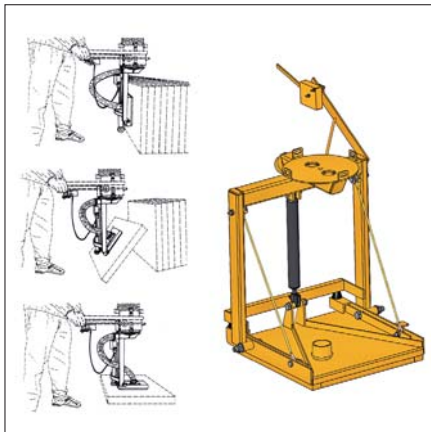

ESP-SW-B-H-VH-150-33/33-0

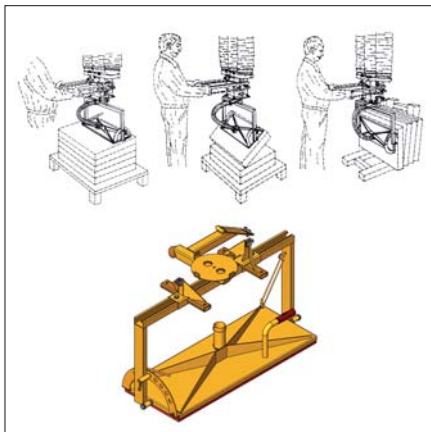

ESP-SW-F-F-250-75/30-A

Tiltable suction plate ESP-SW

With automatic retraction ESP-SW-B:

Specially designed for the laying of slabs, which are delivered to site in vertical position, but have to be placed in horizontal position.

Slabs can be lifted in the vertical position.

Tilting into the horizontal position controlled by pulling a hand lever.

After the installation of the slab in horizontal position, the suction plate retracts itself into vertical position by a gas spring, when the hand lever is pulled once more.

With free swiveling action ESP-SW-F:

Specially designed for handling of slabs in concrete and natural processing factories.

When positioning the suction plate out of the center of gravity on a horizontal slab, the slab is tilting itself into the vertical position when lifted. In this position, the slab can be stored vertically on a transportation pallet.

When positioning in the center of gravity, the slab stays in the horizontal position when lifted.

Suction plate can be locked in different positions by spring loaded bolt.

With integrated suction release device for easier release of the suction plate from the slab element.

Operating of the suction release device only when no load is lifted!

Fastening suitable for Quick Change Adapter SWA-200.

| Type | Dimensions L x W mm (in) | Dead Weight kg (lbs) | Working Load Limit/ WLL -420 mbar kg (lbs) | Angle Pivoting-/Rotation Angle ° Degree | Order-Number |
|---------------------------|-----------------------------|-------------------------|---|--|--------------|
| ESP-SW-B-H-VH-150-33/33-0 | 330 x 330 (12.99 x 12.99) | 12 (26) | 150 (331) | 90 | 42100096 |
| ESP-SW-F-F-250-75/30-A | 750 x 300 (29.53 x 11.81) | 19 (42) | 250 (551) | 90 | 42100095 |
| ESP-SW-F-F-150-40/25-A | 400 x 250 (15¾ x 9.84) | 15 (33) | 150 (331) | 90 | 42100190 |



Pneumatic swivelling base frame for use with exchangeable suction plates ESP-SW-P-250

Developed specifically for handling plate-shaped elements and kerbstones with pneumatic swivelling from vertical to horizontal position and vice versa.

Without suction plate.

- Swivel range of 90° with pneumatic cylinder.
- Can be used on HE-200 and smaller lifting units.
- To improve ergonomics, possibly use handle extension 42300124.

ESP-SW-P-250-A

| Type | Description | Dead Weight kg (lbs) | Working Load Limit/WLL kg (lbs) | Order-Number |
|----------------|----------------------------------|-------------------------|------------------------------------|--------------|
| ESP-SW-P-250-A | Base frame without suction plate | 40.6 (90) | 250 (551) | 42101227 |

Vacuum Hose Lifter Components

- As an alternative to the complete Jumbo Travelling Crane, you can put together a special vacuum-hose-lifter-station, according to your particular needs.
- Pillar and wall swing cranes or other types of cranes can be granted off site.



VGE-230

Vacuum Turbine Unit VGE-230

The blower is connected to a standard household 230 V power supply. All Probst vacuum lifting units from HE-35 to HE-85 can thus be operated without restriction. The vacuum lifting unit HE-150 can also be operated with non porous materials. The fan is controlled with a frequency converter that does not overload the 230V house fuse.

| Type | Type of Drive electric/AC (50 Hz) kW | Electric Voltage /AC (50 Hz) V | Dead Weight kg (lbs) | Order-Number |
|---------|--------------------------------------|--------------------------------|----------------------|--------------|
| VGE-230 | 2.5 | 230 | 77 (170) | 42101425 |



VGE-SB

Vacuum Turbine Unit VGE-SB

Complete, ready-to-run unit for the electrical production of vacuum.
For more difficult use, such as handling of porous elements and high lifting-speed requirements.

Scope of delivery:

VGE-SB-L-EL-EU: Strong, compact housing to be installed on the floor or against the wall. Powerful vacuum turbine with 3-phase electric motor, for maximum low pressure 520 mbar (7,541 psi). With large volume dust-filter with pre-separation for rough conditions in construction industry, including filter-cartridge. With motor-protection switch, pressure relieve valve and electrical plug CEKON 32 A with integrated phase-switch.

| Type | Type of Drive electric/AC (60 Hz) kW | Type of Drive electric/AC (50 Hz) kW | Electric Voltage /AC (50 Hz) V | Electric Voltage /AC (60 Hz) V | Dead Weight kg (lbs) | Order-Number |
|-----------------|--------------------------------------|--------------------------------------|--------------------------------|--------------------------------|----------------------|--------------|
| VGE-SB-L-EL-EU | 4.8 | 4 | 230 / 400 | 265 / 460 | 113 (249) | 47600160 |
| VGE-SB-L-EL-USA | 4.8 | | | 230 / 460 | 113 (249) | 47600161 |
| VGE-SB-L-EL-RU | 4.8 | 4 | 200 / 350 | 220 / 380 | 113 (249) | 47600162 |

Accessories:

Supply Hose: For connecting the turbine unit to the lifting unit. With 2" coupling and 2 hose clamps.

| Type | Description | Diameter inside mm (in) | Dead Weight kg (lbs) | Length mm (in) | Order-Number |
|-------------|--------------|----------------------------|-------------------------|-------------------|--------------|
| Supply Hose | Polyurethane | 60 (2.36) | 10 (22) | 7,000 (275.59) | 42100030 |

Aluminium Smooth Running Cranes for Vacuum Hose Lifters

The vacuum hose lifters eliminate the manual lifting job completely, but swinging the crane arm around or pulling the suspension along the jib can be very burdening when using standard heavy crane systems (indoor use only). The new aluminium crane systems of Probst are now offering ergonomically advantages by smooth running and lightweight design.



AWSK-150

Wall Swing Crane AWSK

If special suction plates, such as tiltable suction plates are used, the lifting height can be less. The static for fixing the crane to the wall has to be checked by the customer. Such as lifting unit HE, operating valve unit BE, vacuum turbines and different suction plates see page 42 – 49.

- The equal load distribution of the rollers of roller suspension eliminates cocking of the suspension, even when pulled sideways.
- Special bearings of the swinging arm and the use of lightweight aluminium are ensuring easy and smooth operation. Special, long lasting rollers.
- Modern design.
- Innovative geometrie of the jib profile.
- Adjustable stops to restrict the the movement along the jib if required.
- Slewing range 180°.
- Optimized height of the jib. Measurement from ground level to the suction plate ESP about 0 to 85 mm (0 to 3 1/4") when the lifting hose is fully extended, depending on the type of suction plate.
- Thus the complete lift of the hose lifter of 1,500 mm (59") can be used.

Scope of delivery:

With adjustable stop, carrier for pipe or cable, roller suspension for hose lifter.

| Type | Load Extension mm (in) | Dead Weight kg (lbs) | Working Load Limit/WLL kg (lbs) | Angle Pivoting-/Rotation Angle °Degree | Order-Number |
|------------|---------------------------|-------------------------|------------------------------------|---|--------------|
| AWSK-150-3 | 3,000 (118.11) | 46 (101) | 150 (331) | 180 | 42000132 |
| AWSK-150-4 | 4,000 (157.48) | 52 (115) | 150 (331) | 180 | 42000126 |
| AWSK-150-5 | 5,000 (196.85) | 81 (179) | 150 (331) | 180 | 42000127 |
| AWSK-300-4 | 4,000 (157.48) | 73 (161) | 300 (661) | 180 | 42000128 |
| AWSK-300-5 | 5,000 (196.85) | 81 (179) | 300 (661) | 180 | 42000129 |

011223 Technical data contained in this catalogue can be modified without prior notice in the interest of progress. Illustrations are exemplary and non-binding. No liability accepted for any misprints, mistakes and errors.



ASSK with lifting hose unit, operating valve unit and suction plate



ASSK-150

Pillar Swing Crane ASSK

Same specifications as Wall Swing Crane AWSK, but slewing range 270°, length and working load limit see tabel.

Important notice:

The assumption for mounting the pillar swing crane using the set of dowels is minimum thickness of the concrete floor of 200 mm (73/4") and a concrete quality C20/25. (Simple installation, no flange plates needed).

Crane height up to bottom edge of crane boom 3200 mm (126 inch).

Optional accessories:

Set of dowels DS-ASSK, consisting of the following components:

Special Anchor with mortar cartridge and bush-es, 8 times threaded M 12, thickness of plate min. 8 mm (1/3") max 25 mm (1").

| Type | Load Extension mm (in) | Dead Weight kg (lbs) | Working Load Limit/WLL kg (lbs) | Angle Pivoting-/Rotation Angle °Degree | Order-Number |
|------------|---------------------------|-------------------------|------------------------------------|---|--------------|
| ASSK-150-4 | 4,000 (157.48) | 167 (368) | 150 (331) | 270 | 42000146 |
| ASSK-150-5 | 5,000 (196.85) | 222 (489) | 150 (331) | 270 | 42000147 |
| ASSK-300-4 | 4,000 (157.48) | 327 (721) | 300 (661) | 270 | 42000124 |
| ASSK-300-5 | 5,000 (196.85) | 414 (913) | 300 (661) | 270 | 42000125 |

Accessories:

| Type | Description | Dead Weight kg (lbs) | Order-Number |
|---------|-------------------------------------|----------------------|--------------|
| DS-ASSK | Set of dowel for pillar swing crane | 2.5 (5.51) | 42000100 |

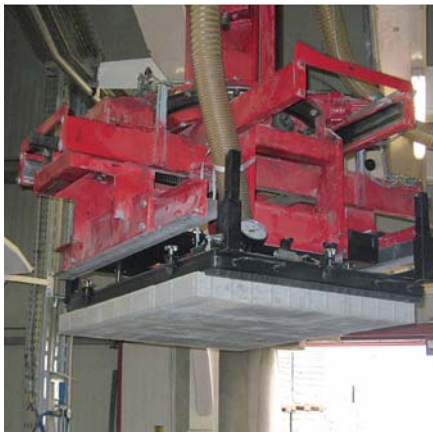

FSG-UNI



P-4



STAZ



STAZ-3 with Three Sides Arms

Grabs for fully automatic plants

Various types of grabs are needed for the efficient handling of construction materials at the concrete plant. Pavers, porous concrete, sand-lime bricks and many more construction materials in various shapes have to be transported, turned and packed. The product range of probst grabs for fully automatic plants can be configured individually to fit to the user-specific challenges!

Vacuum Layer Gripper FSG-UNI

One complete layer of blocks, no matter which shape and which configuration of blocks can be picked up by suction. This allows for complete new design possibilities of shapes. Made to be attached to a hydraulic cubing clamp, a robot or by a lifting unit. Suitable to transport and pack already compacted layers of stone.

ROBOGRIP P-4 Pneumatic Robot Grab

Pneumatic, foursided grab for fully automatic cubing in the concrete stone industry by using an industrial robot. High tensile steel as well as light weight design are minimizing the dead weight of the grab.

Cube Clamp STAZ and Cube Clamp STAZ with Three Side Arms

Extreme stable hydraulic grabs for fully automatic transfer stations. Any configuration in terms of inside height of grab, gripping range, length of gripper, working load limit etc. is possible. Spring loaded pressure plates can stabilize the cube of blocks if required. Also available with swiveling or rotating grippers.

Electric Cubing Clamp ATZ-E-4 and Hydraulic Cubing Clamp ATZ-H-4

Electric or hydraulic two- or foursided cubing clamps for fully automatic cubers in the concrete stone industry. If required available with rotation of the grippers, with distance adjustment of grippers, as double grab, with different kind of grippers etc.



ATZ-E-4



ATZ-H-4



05
A
WE ARE ON LINE VISIT US ON <http://www.jamcpp.com>

C 80461
DUBAI U.A.E.

Truck Crane Attachments

Loading and unloading made easy. Increase your efficiency with optimised handling.



We have developed various types of Block Loading Grabs specially equipped for your needs and loads:

- 1. With fixed height**
- 2. With adjustable height**

For all types we use only the best quality and most reliable components.

- Light weight construction in high tensile steel.
- Large, low-maintenance plastic sliding guides.

The parallel-moveable legs of the clamp are mounted on large dimensioned plastic sliding surfaces. This saves you from having to adjust the bearings and means you only have minimal wear and tear.

5 Year Guarantee on Sliding Guides.

Probst products have been renowned world-wide for decades for their class workmanship and quality. For example we use a highly durable natural rubber with bearing height of 1000 mm (39.37 inch) for the rubber lining on the grippers. This high quality material ensures less wear and tear which results in fewer operation costs.

The rubbers are fixed onto the grippers by means of a robust screw connection. Changing the linings – when they need renewing – is quick.

As the clamp legs are so well constructed and extremely stable, our AKZ only need a small grab between the packs of materials they have to lift. This can be very advantageous when the packs are stacked very close to each other.

All types come with these standard specification:

- Operated hydraulically, smoothly and in parallel
- Manually adjustable pressure reducing valve
- Oil pressure gauge
- 4 Hooks for attaching cables or straps (AKZ-UNI-H only)
- Robust gear rack balance for the absolute synchronous running of the hydraulic cylinders.

Block loading grabs with adjustable height: four different inside height settings can be made via pre-selector lever. A floating position can be pre-selected as an option too.



AKZ-UNI-1230

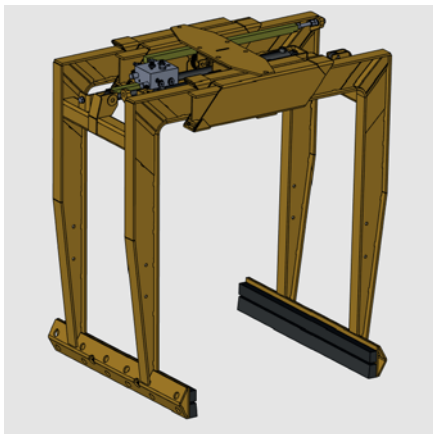

AKZ-UNI

Block Loading Grabs AKZ-UNI with a Fixed Height

Specially designed for use with truck loading cranes. For the transportation of palletised and unpalletised packs of blocks.

In the case of unpalletised stone packages, ensure that the strapping is sufficiently stable.

- Light weight construction in high tensile steel.
- Fully hydraulically adjustable opening range.
- Large, low-maintenance plastic sliding guides.
- Manually adjustable pressure-reducing valve.
- Oil pressure gauge.
- Robust gear rack balance for the absolute synchronous running of the hydraulic cylinders.
- Optional available: 4 screw hooks with safety lock for holding ropes or belts, for example for BigBags. (1 hook per handle). The screw hooks must take the load in equal parts.
- The slide bearings carry a 5 year guarantee.
- The generous opening range and the quick change grippers of various lengths and design make the AKZ adaptable to carry all the usual packs of building materials (see Accessories).

| Type | Inside Height mm (in) | Dead Weight kg (lbs) | Hydraulic Connection Pressure bar (psi) | Opening Width Main Gripper mm (in) | Working Load Limit/WLL kg (lbs) | Gripper Base Length Main Gripper mm (in) | Order-Number |
|--------------|--------------------------|-------------------------|--|---------------------------------------|------------------------------------|--|---------------|
| AKZ-UNI-850 | 850 (33.46) | 310 (683) | 180 – 210 (2,611 – 3,046) | 370 – 1,370 (14.57 – 53.94) | 3,000 (6,614) | 1,000 (39.37) | 56100850-1000 |
| AKZ-UNI-1000 | 1,000 (39.37) | 320 (705) | 180 – 210 (2,611 – 3,046) | 370 – 1,370 (14.57 – 53.94) | 3,000 (6,614) | 1,000 (39.37) | 56101000-1000 |
| AKZ-UNI-1100 | 1,100 (43.31) | 325 (717) | 180 – 210 (2,611 – 3,046) | 370 – 1,370 (14.57 – 53.94) | 3,000 (6,614) | 1,000 (39.37) | 56101100-1000 |
| AKZ-UNI-1230 | 1,230 (48.43) | 345 (761) | 180 – 210 (2,611 – 3,046) | 370 – 1,370 (14.57 – 53.94) | 3,000 (6,614) | 1,000 (39.37) | 56101230-1000 |
| AKZ-UNI-1230 | 1,230 (48.43) | 370 (816) | 180 – 210 (2,611 – 3,046) | 370 – 1,370 (14.57 – 53.94) | 3,000 (6,614) | 1,250 (49.21) | 56101230-1250 |
| AKZ-UNI-1300 | 1,300 (51.18) | 350 (772) | 180 – 210 (2,611 – 3,046) | 370 – 1,370 (14.57 – 53.94) | 2,500 (5,512) | 1,000 (39.37) | 56101300-1000 |

Accessories:

| Type | Description | Dead Weight kg (lbs) | Quantity Pieces | Order-Number |
|--------------------|------------------------|----------------------|-----------------|--------------|
| Screw hook AKZ-UNI | For hanging up BigBags | 2 (4.41) | 1 | 46100444 |



AKZ-UNI-H

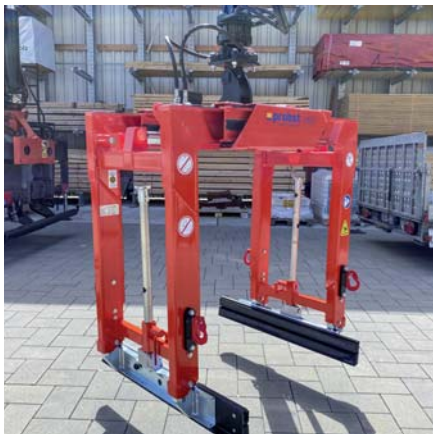

AKZ-UNI-H

Block Loading Grabs AKZ-UNI-H with Adjustable Height

Very robustly designed grab for use on truck-mounted cranes with built in depth adjustment for adapting to building material packages with different heights.

This universal grab type is optimally equipped for the transportation of building material packages of different types and sizes. Due to the variable height adjustment and the large opening range, it can be used for all common building material packages with and without pallets.

Depth adjustment with a choice between floating position and locked.

The different levels are for the following heights:

Level 1 (turned 0°) R 1,100 mm (43")

Level 2 (turned 90°) R 1,280 mm (50")

Level 3 (turned 180°) R 1,470 mm (58")

Level 4 (turned 270°) R 1,650 mm (65")

Due to the optimised steel construction, no pressure when switching between the different depths is necessary – safe gripping of the packages.

- Hydraulically stepless parallel travel.
- Robust gear rack balance for the absolute synchronized running of the hydraulic cylinders.
- Large-surface, low-maintenance plastic sliding guides.
- Manually adjustable pressure-reducing valve.
- Oil pressure gauge.
- 4 screw hooks with safety lock to hold ropes or belts, for example for BigBags. The hooks can also be fitted inside (1 hook per handle). The screw hooks must take the load in equal parts.
- Easy lubrication of the upper and lower sliding guides through attached grease nipples by means of a grease gun. The lubricating grease thus reaches all important places.

| Type | Inside Height mm (in) | Dead Weight kg (lbs) | Hydraulic Connection Pressure bar (psi) | Opening Width Main Gripper mm (in) | Working Load Limit/ WLL kg (lbs) | Gripper Base Length Main Gripper mm (in) | Order-Number |
|------------------|----------------------------------|-------------------------|--|---------------------------------------|-------------------------------------|--|-----------------|
| AKZ-UNI-H | 1,100 – 1,650 (43.31 – 64.96) | 410 (904) | 180 – 210 (2,611 – 3,046) | 370 – 1,370 (14.57 – 53.94) | 1,900 (4,189) | 720 (28.35) | 56100101 |

Spare Parts:

| Type | Description | Dead Weight kg (lbs) | Quantity Pieces | Order-Number |
|---------------------------|------------------------|----------------------|-----------------|-----------------|
| Screw hook AKZ-UNI | For hanging up BigBags | 2 (4.41) | 1 | 46100444 |

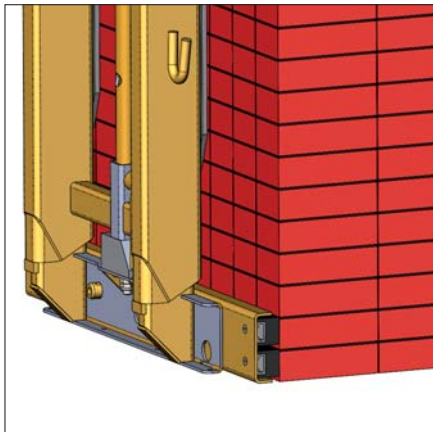

Rubber Gripper GB

Standard models have 2 rows of rubber metal bars.

- Light weight construction to fit all models.
- Choice of shape, lining and length, thus making the block loading grabs suitable to be used everywhere.
- Highly durable exchangeable rubber metal bars are used as gripping elements.

GB2-N: Two identical rubber rails 50 x 45 mm (2 x 1.77 inch).

GB2-Z: 1 x rubber rail 50 x 35 mm (2 x 1.37 inch). 1 x wedge-shaped rubber rail 60 x 40/34.

GB2-N

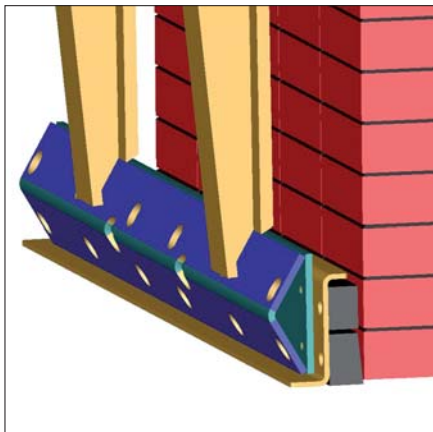

GB2-Z

| Type | Length of Gripper mm (in) | Dead Weight kg (lbs) | Quantity Pieces | Order-Number |
|-------------------|---------------------------|----------------------|-----------------|----------------------|
| GB2-720-N | 720 (28.35) | 11 (24) | 1 | 47451030-0720 |
| GB2-1000-N | 1,000 (39.37) | 15 (33) | 1 | 47451030-1000 |
| GB2-1100-N | 1,100 (43.31) | 17 (37) | 1 | 47451030-1100 |
| GB2-1200-N | 1,200 (47.24) | 22 (49) | 1 | 47451030-1200 |
| GB2-1250-N | 1,250 (49.21) | 24 (53) | 1 | 47451030-1250 |
| GB2-0720-Z | 720 (28.35) | 15.5 (34) | 1 | 47451010-0720 |
| GB2-1000-Z | 1,000 (39.37) | 21.5 (47) | 1 | 47451010-1000 |
| GB2-1200-Z | 1,200 (47.24) | 26 (57) | 1 | 47451010-1200 |
| GB2-1250-Z | 1,250 (49.21) | 27 (60) | 1 | 47451010-1250 |



Accessories for Block Loading Grabs

Quick Change Device SWV

The Quick-Change-Device (SWV) simplifies the suspension of all types of grabs, including those already available, from one crane or from various cranes in a fleet.

When using the SWV quick coupling or screw coupling should be used for high-pressure hoses.

- An enormous amount of setting up time can be saved by using this device if the grab has to be taken down after each load.
- By using the SWV the driver can change over the attachment without additional help.

left: SWV below the rotator. right: SWV above the rotator

| Type | Description | Dead Weight kg (lbs) | Working Load Limit/WLL kg (lbs) | Order-Number |
|------------------------------|---|----------------------|---------------------------------|-----------------|
| SWV below the rotator | The rotator remains on the cranes in normal circumstances. Always state the type of rotator and crane when upon inquiry | 10 (22) | 4,000 (8,818) | 46200001 |
| SWV above the rotator | Rotator remains on clamp. Always state the type of rotator and crane when upon inquiry | 10 (22) | 4,000 (8,818) | 46200002 |

Suspension Link

| Type | Description | Dead Weight kg (lbs) | Working Load Limit/WLL kg (lbs) | Order-Number |
|--------------------------|--|----------------------|---------------------------------|-----------------|
| Below the rotator | For adapting different types of rotary head to the tongs. Always state the type of rotator and crane when upon inquiry | 4 (8.82) | 4,000 (8,818) | 46200072 |
| Above the rotator | For adapting different types of rotator to the crane. Always state the type of rotator and crane when upon inquiry | 4 (8.82) | 4,000 (8,818) | 46200073 |

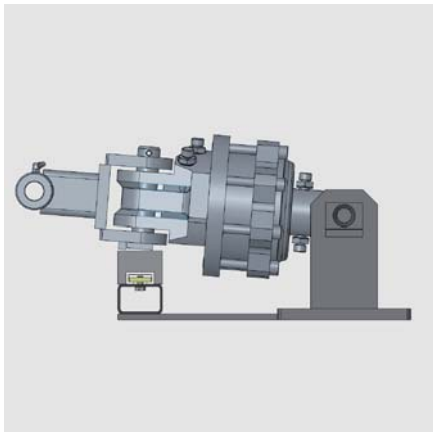

Rotator Tilting Device

The tilting device reduces the overall height of the gripping device including the swivel head. This reduces the overall height of the vehicle when the boom is lowered and mounted. Recommended when using block loading grabs with a high inside height.

Rotator Tilting Device

| Type | Description | Dead Weight kg (lbs) | Working Load Limit/WLL kg (lbs) | Order-Number |
|-------------------------------|-------------------------------|----------------------|---------------------------------|-----------------|
| Rotator Tilting Device | Rotator for shaft | 10 (22) | 4,000 (8,818) | 46200071 |
| Rotator Tilting Device | Rotator for flange-connection | 17 (37) | 4,000 (8,818) | 46200082 |



Hydraulic Rotator

Rotator with hydraulic rotation plus 2 connection hoses to the clamp. Mounted between the gripper and the boom, the rotator enables the exact positioning of the grab when picking up and setting down the stone packs. Rotator also available with pivot.

- Can be mounted directly on the body tongs by means of a flange connection.
- Hydraulic rotary feed-through allows operation of hydraulic consumers with one control circuit.

Rotator

| Type | Dead Weight kg (lbs) | Hydraulic Connection Pressure bar (psi) | Hydr. Volumetric Flow l/min (gpm) | Working Load Limit/WLL kg (lbs) | Angle Pivoting-/Rotation Angle ° Degree | Order-Number |
|--------------------------|----------------------|---|-----------------------------------|---------------------------------|---|-----------------|
| Hydraulic Rotator | 34 (75) | 200 / 250 (2,901 / 3,626) | 22 (5.81) | 4,500 (9,921) | 360 | 46200253 |

011223 Technical data contained in this catalogue can be modified without prior notice in the interest of progress. Illustrations are exemplary and non-binding. No liability accepted for any misprints, mistakes and errors.

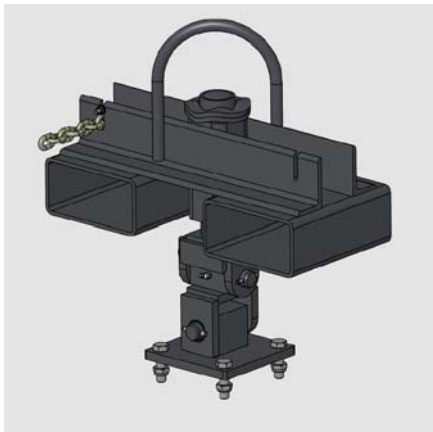

Fork Sleeves with manual device engaging ET

In a hodge after 90°. This means that the AKZ block loading grabs can be picked up with the forks of a wheel loader.

ET-D

15

| Type | Description | Dead Weight kg (lbs) | Working Load Limit/WLL kg (lbs) | Order-Number |
|-------------------------|---|----------------------|---------------------------------|--------------|
| ET-D | Consisting of ET-D, incl. universal joint, mounting plate, for AKZ-UNI-H | 44.6 (98) | 2,500 (5,512) | 43100238 |
| ET 90° incl. cross link | Fork sleeve for fork lift peaks. Suitable e.g. for RK and AKZ-UNI, mounted directly above the gripper including lifting eye for attaching to crane hook. ET 90° design with manual turning device which arrests itself every 90°. | 65 (143) | 4,000 (8,818) | 47110002 |



Not turnable lifting hook DLH

For mounting on a hydraulic rotator to be able to lift loads with a chain hanger.

DHL. left: SWV top. right: DK with pin

| Type | Description | Dead Weight kg (lbs) | Working Load Limit/WLL kg (lbs) | Order-Number |
|------|--------------------------------|----------------------|---------------------------------|--------------|
| DLH | For mounting under DK with pin | 7 (15) | 3,500 (7,716) | 40110077 |
| DLH | For mounting under SWV top | 6 (13) | 3,500 (7,716) | 40110073 |

Hydraulic Accessories

| Type | Dead Weight kg (lbs) | Order-Number |
|--|----------------------|--------------|
| HD plug-in coupling sleeve KM 12L, component 3 | 0.26 (0.57) | 22170002 |
| HD plug-in coupling plug KS 12 L, component 3 | 0.11 (0.24) | 22150007 |
| HD screw coupling sleeve, SKM 12L, component 3 | 0.3 (0.66) | 22170004 |
| Screw coupling plug SKS 12L, component 3 | 0.25 (0.55) | 22150003 |



PGH-15-K

Pallet Forks PGH with load-securing chain

For use with truck loading cranes and fork lift trucks.

Equipped as standard with security chain, thus approved as per rule EN 13155 for transport of individual loads (such as plastic coated, palletized loads).

Approved for use with truck loading cranes for unloading packs of building material at construction sites at near-ground areas without application of security chain.

Adjustable height and fork width (external).

We recommend the Quick Change Device SWV (see page 58) for use with truck loading cranes with a hydraulic rotator.

- Comes with hydraulically operated centre-of-gravity-balance, enabling the forks to tilt forward and backwards in the full and empty position.
- With rotator (additional equipment).
- Standard flange plate to mount the rotator or quick-change-device.
- Forks with long, conical taper for optimal insert underneath the pallets.
- Low payload loss on truck loading crane.
- Light-weight construction due to use of high tensile fine-grain steel.

| Type | Dead Weight kg (lbs) | Hydraulic Connection Pressure bar (psi) | Working Load Limit/WLL kg (lbs) | Fork Dimensions L x W x H mm (in) | Order-Number |
|-----------------|-------------------------|--|------------------------------------|---|-----------------|
| PGH-15-K | 140 (309) | 180 – 210 (2,611 – 3,046) | 1,500 (3,307) | 980 x 100 x 40 (38.58 x 3.94 x 1.57) | 56000010 |
| PGH-20-K | 165 (364) | 180 – 210 (2,611 – 3,046) | 2,000 (4,409) | 980 x 120 x 40 (38.58 x 4.72 x 1.57) | 56000011 |
| PGH-25-K | 230 (507) | 180 – 210 (2,611 – 3,046) | 2,500 (5,512) | 980 x 100 x 45 (38.58 x 3.94 x 1.77) | 56000025 |
| PGH-30-K | 270 (595) | 180 – 210 (2,611 – 3,046) | 3,000 (6,614) | 1,160 x 125 x 45 (45.67 x 4.92 x 1.77) | 56000024 |

Service



Training

Demonstration, technical instructions/assistance

Rental Equipment

Second-hand and demo equipment

Telephone Support

Warranty

Spare parts

Customer service and repair

Phone: +49 7144 3309-30
service@probst-handling.com
WhatsApp +7144 3309-30

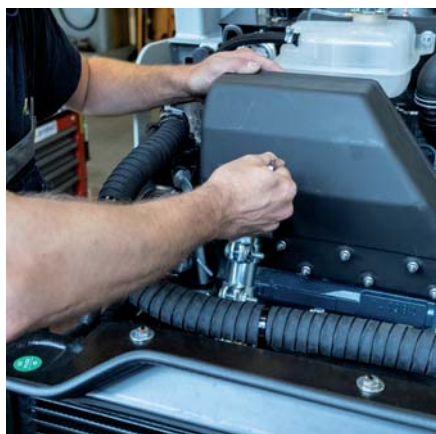

After Sales/Warranty

By purchasing a Probst product you have chosen a quality product which has been developed and tested as a result of over 60 years experience.

For all new catalogue items purchased from 1 January 2024 onwards and the associated accessories from the construction site equipment catalogue, the warranty for products without direct/indirect drive (hydraulic, electric, combustion engine, pneumatic) and without gas struts is 5 years, excluding wearable parts.

For all other new catalogue items purchased from 1 January 2024 onwards and the associated accessories from the construction site equipment catalogue, the warranty is 12 months. This can be extended to 18 months by registering at www.probst-service.com, excluding wearing parts.

For all other newly purchased catalogue items and the associated accessories from the Internal Handling and Truck Attachments section, the warranty is 12 months, excluding wearable parts, and cannot be extended.

In general, all customer-specific items, all non-catalogue items, spare parts, private labels and the baseline range and associated accessories are covered by a 12-month warranty, with the exception of wearable parts, which cannot be extended.

The warranty period for used items is 6 months, with the exception of wearable parts.

If, despite thorough controls, a fault should occur in your Probst product, the complete device should be sent to us, together with the invoice or delivery note and a completed returns form:

Probst GmbH

Technic Centre

Gottlieb-Daimler-Str. 6

71729 Erdmannhausen

Phone + 49 7144 3309 30

E-Mail: service@probst-handling.com

The returns form can be found on our website www.probst-handling.com

An overview of spares can be found in our current operating manual which is supplied with each Probst product. We are happy to send you another copy of this.

If the repair is carried out after the warranty has expired or is due to improper handling, we will send you an estimate of cost together with a request for your approval.

Overview of the Probst service terms and conditions:

| Service provision | Order-Number | Price in Euro |
|---|-----------------|-----------------|
| UVV test Probst small appliances flat rate* | 90010001 | 85,- * |
| UVV test Probst large appliances including Probst accessory* | 90010002 | 160,- * |
| Inspection of electrical work equipment according to VDE 0701-0702 | 90010020 | 30,- * |
| Travelling expenses for service technician visit ¹⁾ | 90010009 | 1,15/km |
| Journey time ¹⁾ | 90010012 | 80/h |
| Working time | 90010011 | 80/h |
| Overnight costs for service technician | 90010010 | 90/Night |

¹⁾ Only the journey will be charged.

* Without spare parts and any possible repair costs incurred.

General sales conditions

1. Preamble

The conditions stated in the following are valid for each order; they exclude the conditions of the Purchaser even if not contradicted expressly. Other Agreements and later modifications are in any case only valid by written confirmation.

2. Offer

All documents belonging to the offer like drawings, indications of weights and measures constitute an approximate guide. The data shall not be binding save to the extent that they are by reference expressly included in the offer. Any drawings or technical documents as well as preliminary quotations and other documents remain the exclusive property of the Vendor. These confidential documents may not, without the Vendors consent, be utilized by the Purchaser or copied, reproduced, transmitted or communicated to a third party. Orders and agreements of all kind need the written confirmation by the Vendor.

3. Prices

The prices are quoted ex works, packing excluded, without engagement. The prices stated in the order-confirmation are fixed, except there are agreed free prices due to long delivery times.

Invoiced will be the prices which are valid on the date of delivery. For orders with a net value of goods up to € 50,- we charge an additional surcharge for small quantities of € 15,-.

4. Delivery

The agreed delivery time starts with the date of order-confirmation, however only if all details regarding the execution of the order will be clarified. Acts of God and other circumstances which are beyond the control of us and of our suppliers like transport disturbances or operating breakdown, lack of material or of parts from suppliers authorize us to claim an adequate extended term.

Purchaser's claims for damages due to failure to perform or delay are excluded if we are not willfully responsible for the damage.

The term of delivery is kept when the product has left the works or it is advised ready for dispatch within the agreed time.

Should delay in delivery be caused by the Purchaser, he will be charged for each month with at least 1/2% of the total invoice amount beginning one month after dispatch date thus covering the costs which arise by storage in the Vendor's works.

The fulfilment of contract by the Purchaser is a precondition for the keeping of delivery times by the Vendor.

5. Packing, Transport, Risk

The kind of packing, way of despatch and shipping route is determined by the Vendor except if there is a special previous agreement.

The costs and risks for the transport of the goods are to be borne by the Purchaser. Provided that no other instructions are given by the Purchaser, we organize the transport by the way that seems best to us without taking responsibility for having chosen the utmost favourable and shortest way.

The Purchaser bears every risk as soon as the merchandise is handed over to the transport agent or carrier.

An insurance against transport damages will only be effected if it is expressly desired by the Purchaser and the costs will be invoiced to him.

In case of transport through the Federal Railway Company or a forwarding agent the Purchaser has to take care of the settlement of his claim by himself. The maturity for our request of payment is not affected.

6. Subject of Contract

The statements regarding measurements, weights, material and services are carefully stated by the Vendor however not binding, except they are expressly determined to be binding. This is also concerning all statements on construction and suggestions for construction. The Vendor reserves the right for modifications due to technical progress. Any drawings, samples or documents of the Vendor remain the exclusive property of the Vendor. They may not without the Vendor's consent be passed on to a third party. This is to point out the Vendor's copyright. The contractual characteristics of the goods are only relating to our product-description and to the written agreements.

Unilateral expectations of the Purchaser as well as advertisements or other comments of the Vendor or his assistants are not taken into consideration.

Demonstration-products, tools and other equipment needed for the execution of an order, remain the Vendor's property, even if the Vendor partially invoices the costs.

7. Guarantee

Provided that it is not about insignificant fault, the Vendor performs under exclusion of other claims for faults of the delivery to which belongs also the absence of strictly guaranteed or guaranteed qualities, guarantee as follows:

For all new catalogue items purchased from 1 January 2024 onwards and the associated accessories from the construction site equipment catalogue, the warranty for products without direct/indirect drive (hydraulic, electric, combustion engine, pneumatic) and without gas struts is 5 years, excluding wearable parts.

For all other new catalogue items purchased from 1 January 2024 onwards and the associated accessories from the construction site equipment catalogue, the warranty is 12 months. This can be extended to 18 months by registering at www.probst-service.com, excluding wearing parts.

For all other newly purchased catalogue items and the associated accessories from the Internal Handling and Truck Attachments section, the warranty is 12 months, excluding wearable parts, and cannot be extended.

In general, all customer-specific items, all non-catalogue items, spare parts, private labels and the baseline range and associated accessories are covered by a 12-month warranty, with the exception of wearable parts, which cannot be extended.

The warranty period for used items is 6 months, with the exception of wearable parts.

Rubber bars used as gripping elements are wear articles and are not subject to the guarantee. Faults by incorrect assembly or initial start-up, unsuitable or inappropriate use or changes or repairs by the Purchaser or third persons, natural wear, incorrect or careless treatment, excessive strain, unsuitable methods of operation, exchange materials, chemical, electro-chemical or electric influences expels every guarantee, provided that they are not to be led back on a fault of the Vendor. Further rights, particularly claims to substitute of the losses which have not appeared in the subject of delivery themselves, are expelled.

Notices of defect within the above stated frame are only recognized if they are asserted within two weeks after reception of the goods, with first not recognizable fault immediately after knowledge by written statement. Objections on the amount are only considered if they are brought forward immediately on receipt of the consignment in written form. The examination and reprimand obligation also encloses operating instructions and assembly instructions.

Also damages which are subject to the guarantee have to be indicated immediately in writing. A claim to transformation or decrease does not exist, unless we are not able the lack to repair. To the realization of all repairs inevitably appearing to the Vendor and substitute deliveries the customer after communication with the Vendor has to give the required time and opportunity, otherwise the Vendor is freed from the liability for defects.

Only in pressing cases of the endangering of the operational safety and to avoid disproportionately big losses, whereby the Vendor is to be informed immediately, or if the Vendor is in delay with the removal of the lack, the customer has the right to allow to remove the lack by third persons and has a claim for reimbursement of wasted expenditure towards the Vendor. Further claims, e.g., substitute of wage or spoiled equipment, etc., are expelled.

General sales conditions

Repair or substitute is our choice. If the parts are returned not free of charge so they will be sent back also not free, i.e. a freight way is carried by us with the cheapest way of dispatch. The guarantee expires if the subject of delivery is treated by foreign party, also with pressure of time an other treatment needs our consent in particular. We are not responsible for failures as a result of bad assembly by the customer or third persons, of bad maintenance or carelessness, of unsuitable or inappropriate use or of excessive use.

Precondition for the guarantee is the fulfillment of the contractual obligations by the Purchaser. Because of the notices of defect about which no doubt exists, payments may be held back only in the appropriate relation to the appeared lack. Particularly no compensations may take place against earlier or later deliveries. Returns need the previous agreement of the Vendor.

8. Right to rescind of the Purchaser and other liability of the Vendor

The Purchaser can withdraw from the contract if the whole performance is definitively impossible before risk transfer or the delivery within an appropriate term which may not remain under a month, did not take place, unless, the performance hindrance is to be represented from the Vendor at least mainly or it is about a case of point 6. paragraph 4. As far as partial performances are possible and for the Purchaser useful also after ending of the contract, the right to rescind limits itself to the parts not yet performed.

If the impossibility enters during the acceptance delay or by fault of the Purchaser, he remains obliged to do the settlement. If partial performances have already taken place for the purposes of the paragraph 1, a compensation claim also exists in this respect. The Purchaser has furthermore a right to rescind if the Vendor has passed inactively an adequate extension placed to him for the repairing or reworking due to a failure to be represented by the Vendor in the sense of these terms of delivery. If the Vendor decides on an extended elimination of the lack, the Purchaser only has a right to rescind if the elimination of the lack has failed two times. The appropriate extension does not begin earlier, than the lack and the representation obligation of the Vendor are determined and proved. The Purchaser can also assert reduction instead of his right to rescind. If the Purchaser or a third person makes inappropriate changes or repairs without previous approval of the Vendor, there is no liability of the Vendor for the consequences appearing from it.

The liability of the Vendor is determined exclusively according to the preceding points of this agreement. All not strictly admitted rights there, e.g., on delivery of a faultless product, resignation of the contract or decrease as well as on substitute of losses of every kind, namely also from such losses which have not appeared in the subject of delivery and regardless of any legal argument, are excluded. This exclusion of liability applies not with intention and gross negligence of legal representatives or fulfillment assistants and by culpable violation of main liability. The exclusion of liability finds no further application if qualities which are strictly guaranteed are missing, if the warranty has just aimed to safeguard the buyer against the losses which have not appeared in the subject of delivery themselves, as well as if the damage is based on a circumstance, for which the Vendor has taken over a guarantee. The same applies if a procurement risk realizes which the Vendor has explicitly taken over. Finally, the exclusion of liability applies not in that cases in which according to the country right valid in each case a damages obligation exists which can not be expelled by contract, particularly for product liability. Except for losses for life, body and health and for intention and coarse negligence of legal representatives and fulfillment assistants, the extent of the damage to be replaced is limited however, on foreseeable losses.

9. Payment

The settling place for payment and the currency are agreed especially. A delay in payment or a setting off is only acceptable in case of undisputed or legally binding counter-claims. If the financial situation of the Purchaser gets worse after agreement to the contract essentially and is thereby endangering the payment entitled to the Vendor, the Vendor is entitled to refuse the performance, until the settlement is effected or is performed safely for him.

10. Delay in Payment

If the Purchaser does not keep to the arranged term of payment, we charge from maturity for interests by the legal height according to German law. Before payment of payable amounts the Vendor is not obliged to do any other delivery, as far as the Purchaser does not perform safety for this. In case of outstanding overdue payment, indebted by the Purchaser, all unpaid invoices of the Vendor become immediately payable.

11. Retention of title of ownership

Up to entire satisfaction of all claims from the business connection remain the supplied goods property of the Vendor. The Purchaser has to keep the goods duly and to insure them. If the Purchaser is late with payable payments in more than 10 workdays the Purchaser is obliged on demand of the Vendor to return the supplied goods, without the Vendor must explain before the withdrawal of the contract.

12. Acceptance, call, right to rescind of the Vendor

On call bought goods are to be accepted within a month after demand to takeover. If the Purchaser is in acceptance delay, the Vendor can store the goods at the expenses and risk of the Purchaser and can invoice him all expenses appearing from it. The same applies if due to circumstances attributed to the Purchaser, goods ready for dispatch can not be dispatched. If the Purchaser continues to delay acceptance of the goods in spite of passed time-limit, is a payable payment more than 30 days in the delay or commits the Purchaser another weighty breach of the contract, the Vendor is entitled to the withdrawal of the contract and to claim for damages.

13. Arbitration board, place of delivery, other rights

The rights of the Purchaser are not transferable. The legal ineffectiveness or change of single regulations do not touch the validity of the rest regulations.

To the place of an ineffective regulation that permissible regulation should step which comes to the economic thought of the ineffective regulation in the next. Place of delivery for all deliveries is the manufacturing work of the Vendor, in Erdmannhausen, as far as no divergent agreement has been met. The preceding conditions apply to every order. Other conditions are for the Vendor only bindingly if he has recognized them in writing.

On the contract the right of the Federal Republic of Germany is applicable under exclusion of the agreement of the United Nations from the 11/04/1980 about contracts about the international goods purchase.

All disputes which arise in connection with the contract or about its validity, are decided according to the arbitration board order of the German Institution for Arbitration Board Ability Inc (DIS) under exclusion of the neat course of law finally. The arbitration board also can make a binding decision about the validity of this arbitration agreement.

The right solution for every challenge – already in the range, or we construct it.

Probst makes hard work easier. We already have available a wide range of machines, equipment and tools for many applications. We will gladly help you find the right solution for you. Alternatively, we can develop an individual suitable solution for you. For the optimal consultation, simply send us your requirements in advance..

Contact person: _____ Company: _____

Phone: _____ E-mail address: _____

Please describe the element to be lifted.

Dimensions (LxWxH in mm)

Weight (in kg)

What material is the element made of?

e.g. concrete, natural stone, granite, limestone, ...

What is the surface finish?

e.g. coated, structured, smooth, polished, powder-coated, ...

How is the element stored or how is it delivered?

If available, please send us sketches or photos.

What is the intended location?

e.g. building site, building material plant, desert, sea air, ...

Which drive is preferred or available?

e.g. combustion engine, hydraulic or electric drive, ...

Is a carrier device provided? If so, which?

e.g. excavator, forklift, loading crane, overhead crane, chain hoist, ...

When do you plan to commission the unit?

Is there any other relevant information?

You will find space for a sketch or drawing of the element on the following page.

Please take photos of this page and your sketches and send them to: info@probst-handling.de

Alternatively, use our online form and send us your request digitally:
www.probst-handling.com/en/productrequest

We are looking forward to your request and will contact you immediately.

Sketch/drawing

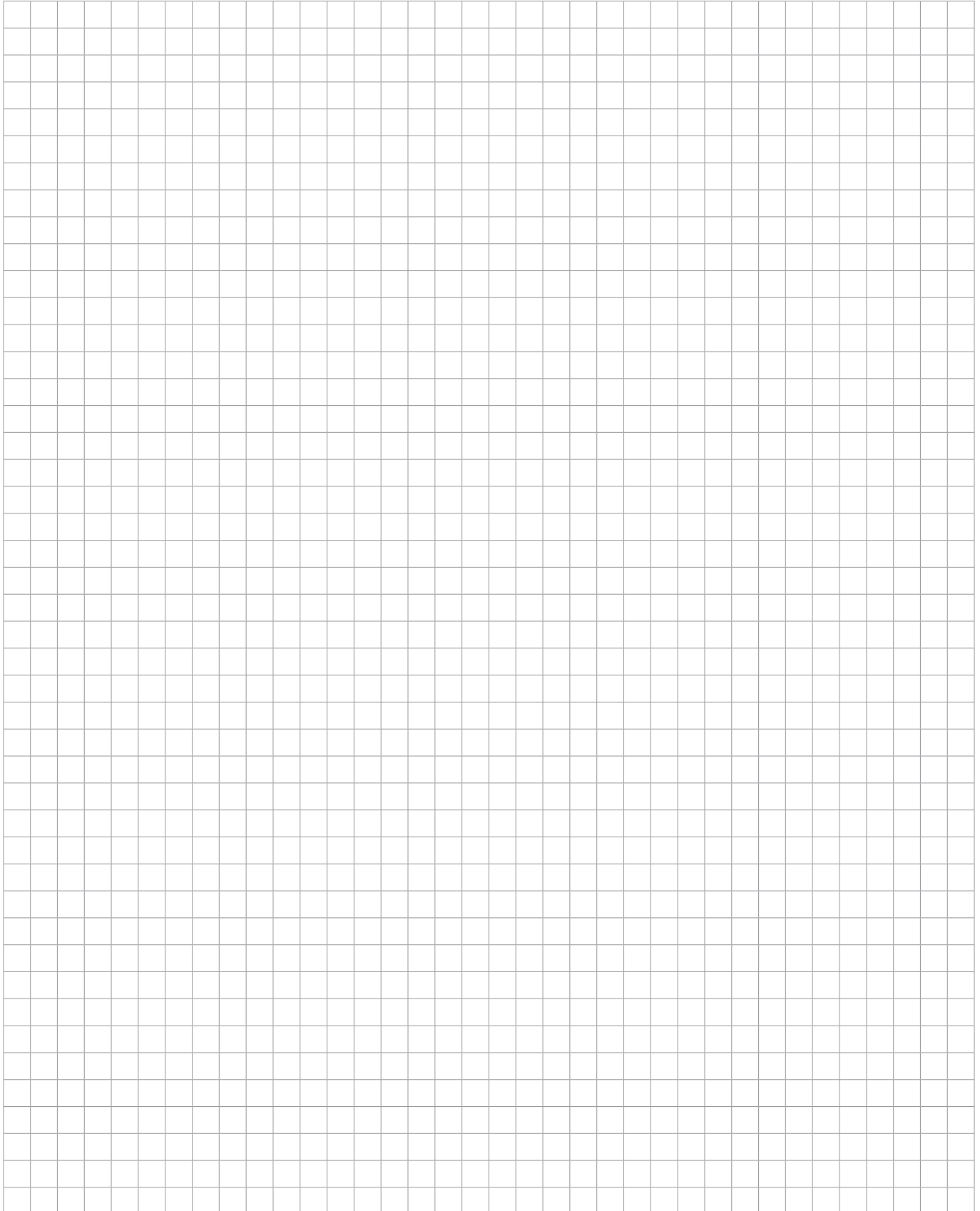
A large, empty grid of small squares, intended for drawing or sketching a product. The grid consists of 20 columns and 30 rows of squares.



making hard work easier



Site Equipment



Building Material Plants –
In-Plant Handling



Truck Crane Attachments

Probst GmbH
Gottlieb-Daimler-Straße 6
71729 Erdmannhausen, Germany
+49 7144 3309-30
info@probst-handling.com

www.probst-handling.com